

FURNITURE CATALOGUE

We produce furniture
of the highest quality.





Discover our wide
range of products.





TABLE OF CONTENTS

"MODERN" CLOTHING LOCKERS	3
"L" MODERN CLOTHING LOCKERS.....	5
FIRE STATION LOCKERS.....	7
"MODERN" MULTI-COMPARTMENT LOCKERS	8
'SLIM' SCHOOL AND PRESCHOOL LOCKERS	13
COMPARTMENT LOCKERS FOR CLEAN CLOTHES	15
COMPARTMENT LOCKERS FOR DIRTY CLOTHES	16
FOOD LOCKERS	18
WALL-MOUNTED FOOD LOCKERS	19
MOBILE PHONE LOCKERS	21
UTILITY LOCKERS.....	22
ROOFS INCLINED AT 30 DEGREES.....	23
FIXED BENCHES UNDER THE LOCKER	24
FIXED BENCHES UNDER THE LOCKER, WITH SHOE SHELF	25
RETRACTABLE BENCHES UNDER THE LOCKER.....	26
RETRACTABLE BENCHES UNDER THE LOCKER, WITH SHOE SHELF.....	27
RETRACTABLE BENCHES UNDER THE LOCKER, WITH 2 LOCKERS	28
BENCH-HEIGHT PLATFORMS UNDER THE LOCKER (new in 2018)	29
BENCH-HEIGHT PLATFORMS UNDER THE LOCKER, WITH SHOE SHELF (new in 2018)	30
FREE-STANDING BENCHES.....	31
FREE-STANDING BENCHES, WITH SHOE SHELF	32
BENCHES WITH COAT RACKS.....	33
HIGH OFFICE CABINETS.....	35
LOW OFFICE CABINETS	37
OFFICE AND CLOTHING CABINET.....	38
DOUBLE OFFICE CABINET.....	38
DOUBLE CLOTHING CABINET	39
OFFICE AND FILE CABINETS	39

HEIGHT EXTENSION UNITS FOR OFFICE CABINETS, DOUBLE OFFICE CABINETS, OFFICE AND CLOTHING CABINETS, AND OFFICE AND FILES CABINETS	41
FILE CABINETS	43
MAP AND PLAN CABINETS	46
DESKS	48
TECHBOX METAL BOXES	55
RECYCLING BINS	56
SPORT LOCKERS	59
LIGHT WORKBENCHES	64
HEAVY-DUTY WORKBENCHES	66
CUSTOMISED WORKBENCHES	73
FREE-STANDING WORKSHOP CUPBOARDS	81
WALL-MOUNTED WORKSHOP CUPBOARDS	84
WORKSHOP CARTS	85
WORKSHOP CABINETS	88
CUSTOM-MADE WORKSHOP CABINETS	96
WORKSHOP CABINETS FOR CHEMICAL SUBSTANCES	103
STANDS FOR WORKSHOP CONTAINERS	105
TYPES OF MOUNTS FOR THE WORKSHOP CABINETS	107
TYPES OF CONTAINERS FOR THE WORKSHOP FURNITURE	109
COMPUTER + COMPUTER WITH LCD MONITOR CABINETS	110
HIGH LAPTOP CABINETS	113
LAPTOP CARTS	114
RACKS	116
MEDICAL CABINETS	118
WALL-MOUNTED MEDICAL CUPBOARDS	120
FREE-STANDING MEDICAL CUPBOARDS	121
MEDICAL DESK	122
MEDICAL FILE CABINETS	123

"MODERN" CLOTHING LOCKERS			
	<p>Welded structure of the lockers, - specially designed door guarantee high stiffness, - doors provided with modern perforation and a place for ID sticker, - each compartment includes a shelf and a rail with two hooks, - back and side walls of the lockers are provided with openings to couple the lockers with screws. - lockers provided with key-locks with 1-point locking, - lockers made of metal plate, 0.6 mm thick</p> <p><i>Lockers painted with all RAL colours. Delivered lockers are completely assembled.</i></p>		
	SKU	DIMENSIONS [mm] H x W x D (WEIGHT [kg])	ADDITIONAL DESCRIPTION
1- column			
	SzUM 315K1	1800 x 315 x 490 (16)	With 1-point locking
			With 3-point locking
	SzUM 415K1	1800 x 415 x 490 (21)	With 1-point locking
			With 3-point locking
2- column			
	SzUM 600K2	1800 x 600 x 490 (28)	With 1-point locking
			With 3-point locking
	SzUM 800K2	1800 x 800 x 490 (41)	With 1-point locking
			With 3-point locking
			A wall inside the compartment separates PPE from the user's casual wear

3- column				
	SzUM 885K3	1800 x 885 x 490 (40)	With 1-point locking	
	SzUM 1185K3	1800 x 1185 x 490 (61)	With 1-point locking	A wall inside the compartment separates PPE from the user's casual wear
			With 3-point locking	
4- column				
	SzUM 1175K4	1800 x 1175 x 490 (53)	With 1-point locking	
			With 3-point locking	



"L" MODERN CLOTHING LOCKERS



- Welded structure of the lockers,
- specially designed door guarantee high stiffness,
 - doors provided with modern vent grills and a place for ID sticker,
 - each compartment includes a rail with two hooks,
 - back and side walls of the lockers are provided with openings to couple the lockers with screws.
 - lockers provided with key-locks with single-point locking,

Lockers painted with all RAL colours.

Delivered lockers are completely assembled.

	SKU	DIMENSIONS [mm] H x W x D (WEIGHT [kg])	ADDITIONAL DESCRIPTION
1- column			
	SzLM 300K1/2	1800 x 300 x 490 (20)	with 1-point locking
	SzLM 400K1/2	1800 x 400 x 490 (23)	with 1-point locking
2- column			
	SzLM 600K2/2	1800 x 600 x 490 (36)	with 1-point locking
	SzLM 800K2/2	1800 x 800 x 490 (39)	with 1-point locking
3- column			
	SzLM 900K3/2	1800 x 900 x 490 (55)	with 1-point locking

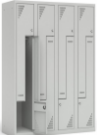
	SzLM 1200K3/2	1800 x 1200 x 490 (59)	with 1-point locking
	SzLM1200K4 /2	1800 x 1200 x 490 (65)	With 1-point locking

LOCKING SYSTEMS AVAILABLE IN MODERN CLOTHING LOCKERS

Double-key lock without Master key

Double-key lock with Master key

Locking mechanism for padlock

Coded lock with 1-point locking (1 pc.)

Coded lock with 3-point locking (1 pc.) (not applicable to SzL)

Coin-operated lock with 1-point locking (1 pc.)

ADDITIONAL EQUIPMENT OPTIONS AVAILABLE IN MODERN CLOTHING LOCKERS:

Levelling feet (4 pcs.)

Stands 100 mm high (4 pcs.)

Numbering stickers (1 pc.)

Metal numbering (1 pc.)



Door stop (1 pc.)

Mirror (1 pc.)

Extra metal hook (1 pc.)

Extra plastic hook (1 pc.)

Extra shoe shelf (1 pc.) *(not applicable to SZL)*

FIRE STATION LOCKERS			
 <p>Welded structure of the lockers,</p> <ul style="list-style-type: none"> - upper security compartment provided with a key-lock with single-point locking, - main compartment provided with a shelf, a rail and two hooks (one sliding plastic hook on the rail, one metal hook welded permanently on the side wall) - top surface of the locker provided with a helmet stand, - side walls of the lockers are provided with openings to couple the lockers with screws. <p><i>Lockers painted with all RAL colours. Delivered lockers are completely assembled.</i></p>			
	SKU	DIMENSIONS [mm] H x W x D (WEIGHT [kg])	ADDITIONAL DESCRIPTION
	SzU/ OSP1	1950 x 400 x 550 (16)	
	SzU/ OSP2	1950 x 800 x 550 (27)	







ADDITIONAL EQUIPMENT OPTIONS AVAILABLE IN FIRE STATION LOCKERS
Levelling feet (4 pcs.)
Stands 100 mm high (4 pcs.)
Extra metal hook (1 pc.)
Extra plastic hook (1 pc.)
Extra shoe shelf (1 pc.)









"MODERN" MULTI-COMPARTMENT LOCKERS









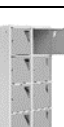

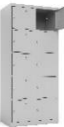

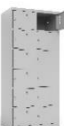





- welded structure of the multi-compartment locker, specially designed door guarantee high stiffness,
- doors provided with modern perforation and a place for ID sticker,
- back and side walls of the lockers are provided with openings to couple the lockers with screws.
- lockers provided with key-locks with single-point locking,
- made of metal plate, 0.6 mm thick

*Lockers painted with all RAL colours.
Delivered lockers are completely assembled.*

	SKU	DIMENSION S [mm] H x W x D (WEIGHT [kg])	ADDITIONAL DESCRIPTION
1- Column			
2- compartment	 SzSM 2/315K1	1800 x 315 x 490 (17)	Each compartment includes a rail and two hooks
	 SzSM 2/415K1	1800 x 415 x 490 (19)	
3- compartment	 SzSM 3/315K1	1800 x 315 x 490 (18)	
	 SzSM 3/415K1	1800 x 415 x 490 (20)	
4- compartment	 SzSM 4/315K1	1800 x 315 x 490 (18)	
	 SzSM 4/415K1	1800 x 415 x 490 (20)	

5- compartment		SzSM 5/315K1	1800 x 315 x 490 (18)	
		SzSM 5/415K1	1800 x 415 x 490 (20)	
6- compartment		SzSM 6/315K1	1800 x 315 x 490 (18)	
		SzSM 6/415K1	1800 x 415 x 490 (20)	
2 - column				
4 - compartment		SzSM 2/600K2	1800 x 600 x 490 (27)	Each compartment includes a rail and two hooks
		SzSM 2/800K2	1800 x 800 x 490 (32)	
6 - compartment		SzSM 3/600K2	1800 x 600 x 490 (28)	
		SzSM 3/800K2	1800 x 800 x 490 (33)	
8 - compartment		SzSM 4/600K2	1800 x 600 x 490 (29)	
		SzSM 4/800K2	1800 x 800 x 490 (33)	

10 - compartment		SzSM 5/600K2	1800 x 600 x 490 (29)	
		SzSM 5/800K2	1800 x 800 x 490 (34)	
12 - compartment		SzSM 6/600K2	1800 x 600 x 490 (30)	
		SzSM 6/800K2	1800 x 800 x 490 (34)	
3 - column				
6 - compartment		SzSM 2/885K3	1800 x 885 x 490 (39)	Each compartment includes a rail and two hooks
		SzSM 2/1185K3	1800 x 1185 x 490 (45)	
9 - compartment		SzSM 3/885K3	1800 x 885 x 490 (39)	
		SzSM 3/1185K3	1800 x 1185 x 490 (47)	
12 - compartment		SzSM 4/885K3	1800 x 885 x 490 (40)	
		SzSM 4/1185K3	1800 x 1185 x 490 (48)	

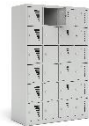
15 – compartment		SzSM 5/885K3	1800 x 885 x 490 (41)	
		SzSM 5/1185K3	1800 x 1185 x 490 (48)	
18 – compartment		SzSM 6/885K3	1800 x 885 x 490 (41)	
		SzSM 6/1185K3	1800 x 1185 x 490 (49)	
4 – column				
8 – compartment		SzSM 2/1175K4	1800 x 1175 x 490 (60)	Each compartment includes a rail and two hooks
12-		SzSM 3/1175K4	1800 x 1175 x 490 (50)	
16-		SzSM 4/1175K4	1800 x 1175 x 490 (53)	
20-		SzSM 5/1175K4	1800 x 1175 x 490 (56)	
24-		SzSM 6/1175K4	1800 x 1175 x 490 (58)	

5 - column				
10 - compartment		SzSM 2/1460K5	1800 x 1460 x 490 (75)	Each compartment includes a rail and two hooks

LOCKING SYSTEMS AVAILABLE IN MODERN MULTI-COMPARTMENT LOCKERS

- Double-key lock without Master key
- Double-key lock with Master key
- Locking mechanism for padlock
- Coded lock with 1-point locking (1 pc.)
- Coin-operated lock with single-point locking (1 pc.)

ADDITIONAL EQUIPMENT OPTIONS AVAILABLE IN MODERN MULTI-COMPARTMENT LOCKERS:

- UV printing (with modern perforation) (1 door)
- Levelling feet (4 pcs.)
- Stands 100 mm high (4 pcs.)
- Numbering sticker (1 pc.)
- Metal numbering (1 pc.)
- Door stop (1 pc.)
- Mirror (1 pc.)
- Extra metal hook (1 pc.)
- Extra plastic hook (1 pc.)
- Extra shoe shelf (1 pc.)
- Extra book shelf (1 pc.)

'SLIM' SCHOOL AND PRESCHOOL LOCKERS





Welded structure of the lockers, lockers made on 0,6mm thick steel

- specially designed door guarantee high stiffness,
- each compartment includes a rail and 2 plastic hooks
- modern perforation on doors,
- back and side walls of the lockers are provided with openings to couple the lockers with screws,
- lockers locked with a key lock with 1-point blocking

*Lockers painted with all RAL colours.
Delivered lockers are completely assembled.*

		SKU	DIMENSIONS[m] H x W x D (WEIGHT [kg])	ADDITIONAL DESCRIPTION
1 – column				
2- compartment		SzSSL 2/260K1/1500	1500 x 260 x 400	Door clearance[mm] 690 H x 177 W
		SzSSL 2/260K1/1800	1800 x 260 x 400	Door clearance[mm] 840 H x 177 W
2 – column				
4- compartment		SzSSL 2/495K2/1500	1500 x 495 x 400	Door clearance[mm] 690 H x 177 W
		SzSSL 2/495K2/1800	1800 x 495 x 400	Door clearance[mm] 840 H x 177 W
3 – column				
6- compartment		SzSSL 2/730K3/1500	1500 x 730 x 400	Door clearance[mm] 690 H x 177 W
		SzSSL 2/730K3/1800	1800 x 730 x 400	Door clearance[mm] 840 H x 177 W

4 – column				
8- compartment		SzSSL 2/965K4/1500	1500 x 965 x 400	Door clearance[mm] 690 H x 177 W
		SzSSL 2/965K4/1800	1800 x 965 x 400	Door clearance[mm] 840 H x 177 W
5 – column				
10- compartment		SzSSL 2/1200K5/1500	1500 x 1200 x 400	Door clearance[mm] 690 H x 177 W
		SzSSL 2/1200K5/1800	1800 x 1200 x 400	Door clearance[mm] 840 H x 177 W

LOCKING SYSTEMS AVAILABLE IN THE 'SLIM' SCHOOL AND PRE-SCHOOL LOCKERS:

Double-key lock without Master key

Double-key lock with Master key

Locking mechanism for padlock

Coded lock with 1-point locking (1 pc.)

ADDITIONAL EQUIPMENT OPTIONS AVAILABLE IN 'SLIM':

UV printing (with modern perforation) (1 door)

Levelling feet (4 pcs.)

Stands 100 mm high (4 pcs.)

Numbering stickers (1 pc.)

Metal numbering (1 pc.)







Door stop (1 pc.)

Mirror (1 pc.)

Extra metal hook (1 pc.)

Extra plastic hook (1 pc.)

Extra shoe shelf (1 pc.)

COMPARTMENT LOCKERS FOR CLEAN CLOTHES				
		<p>Welded structure of the compartment lockers for clean clothes,</p> <ul style="list-style-type: none"> - main door frame opens all compartments at one go, it is locked with a key-lock with Master key and 1-point locking, - each compartment is locked with a change key with 1-point locking, being a part of master keying system, - each compartment door is provided with a place for an identifier. <p><i>Lockers painted with all RAL colours. Delivered lockers are completely assembled.</i></p>		
		SKU	DIMENSION S [mm] H x W x D (WEIGHT [kg])	ADDITIONAL DESCRIPTION
1- column				
5- compartment		SzC 5K1	1970 x 420 x 410 (37)	
10- 10compartment		SzC 10K1	1970 x 420 x 410 (35)	
2- column				
10- compartment		SzC 5K2	1970 x 751 x 410 (55)	
20- compartment		SzC 10K2	1970 x 751 x 410 (50)	
24- compartment		SzC 12K2	1970 x 751 x 410 (49)	

COMPARTMENT LOCKERS FOR DIRTY CLOTHES



- Welded structure of the compartment lockers for dirty clothes,
- compartment door provided with reinforcement frame, it is locked with a key-lock with Master key and 1-point locking,
 - collector opening with hinged door of 370 mm x 165 mm
 - perforated bottom and vent openings on the back wall,
 - 4 hooks welded on the inner surface of the walls to hang the laundry sack from the inside,
 - adjustable stands of 50 mm,

*Lockers painted with all RAL colours.
Delivered lockers are completely assembled.*

	SKU	DIMENSIONS [mm] H x W x D (WEIGHT [kg])	ADDITIONAL DESCRIPTION
	SzB	1970 x 420 x 410 (38)	

LOCKING SYSTEMS AVAILABLE IN LOCKERS FOR CLEAN AND DIRTY CLOTHES:

- Double-key lock without Master key
- Double-key lock with Master key
- Locking mechanism for padlock
- Coded lock with 1-point locking

ADDITIONAL EQUIPMENT OPTIONS AVAILABLE IN LOCKERS FOR CLEAN AND DIRTY CLOTHES:

- Levelling feet (4 pcs.)
- Stands 100 mm high (4 pcs.)
- Numbering sticker (1 pc.)
- Metal numbering (1 pc.)

ROOFS INCLINED AT 45 DEGREES FOR LOCKERS WITH CLEAN AND DIRTY CLOTHES











Roof inclined at 45 degrees is an optional element to be used with the lockers for clean and dirty clothes.

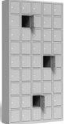



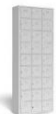

The whole roof is made of metal plate and coated with powder paint. The roof is assembled on the locker top to keep the furniture clean.

Roofs can be painted with any RAL colour.

Our products are covered by 24-months warranty.

SKU	DIMENSIONS [mm] H x W x D (WEIGHT [kg])	TAILORED TO THE FOLLOWING TYPES OF FURNITURE
DSZ 420	405 x 420 x 410 (4)	SzC 5K1, SzC 10K1, SzB
DSZ 751	405 x 751 x 410 (8)	SzC 10K2, SzC 12K2

FOOD LOCKERS				
		<p>Welded structure of the compartment food lockers ,</p> <ul style="list-style-type: none"> - each compartment is locked with a change key with 1-point locking, being a part of master keying system, - each compartment door is provided with a place for an identifier, <p><i>Lockers painted with all RAL colours.</i></p> <p><i>Delivered lockers are completely assembled.</i></p>		
		SKU	DIMENSIONS [mm] H x W x D (WEIGHT [kg])	USEFUL COMPARTMENT DIMENSIONS H x W x D [mm]
1- column				
10 - compartment		SzS 10/420K1	1970 x 420 x 300 (28)	176 x 365 x 276
2- column				
18 - compartment		SzS 9/500K2	2000 x 500 x 300 (36)	197 x 203 x 276
20 - compartment		SzS 10/751K2	1970 x 751 x 300 (42)	171 x 328 x 276
3- column				
27 - compartment		SzS 9/750K3	2000 x 750 x 300 (51)	196 x 196 x 276
30 - 30compartment		SzS 10/1120K3	1970 x 1120 x 300 (59)	171 x 331 x 276
4- column				
36 - 36compartment		SzS 9/800K4	2000 x 800 x 300 (68)	196 x 148 x 276
5- column				
45 - compartment		SzS 9/1000K5	2000 x 1000 x 300 (85)	196 x 148 x 276

WALL-MOUNTED FOOD LOCKERS				
		<p>Welded structure of the compartment food lockers ,</p> <ul style="list-style-type: none"> - each compartment is locked with a change key with 1-point locking, being a part of master keying system, - each compartment door is provided with a place for an identifier, - back of the locker is provided with openings to mount it on the wall, - roof inclined at 63 degrees integrated with the locker. <p><i>Lockers painted with all RAL colours. Delivered lockers are completely assembled.</i></p>		
		SKU	DIMENSIONS [mm] H x W x D (WEIGHT [kg])	USEFUL COMPARTMENT DIMENSIONS H x W x D [mm]
1- column				
5 - compartment		SzS W 5/270K1	1280 x 270 x 300	194 x 197 x 276
2 - column				
10 - compartment		SzS W 5/510K2	1280 x 510 x 300	198 x 198 x 276
3 - column				
15 - compartment		SzS W 5/750K3	1280 x 750 x 300	198 x 198 x 276
4 - column				
20 - compartment		SzS W 5/990K4	1280 x 990 x 300	198 x 198 x 276
5 - column				
25 - compartment		SzS W 5/1235K5	1280 x 1235 x 300	198 x 198 x 276

LOCKING SYSTEMS AVAILABLE IN FOOD LOCKERS:

Double-key lock without Master key
Double-key lock with Master key
Locking mechanism for padlock
Coin-operated lock with 1-point locking (1 pc.)
Coded lock with 1-point locking (1 pc.)

ADDITIONAL EQUIPMENT OPTIONS AVAILABLE IN FOOD LOCKERS:



Levelling feet (4 pcs.)
Stands 100 mm high (4 pcs.)
Numbering sticker (1 pc.)
Metal numbering (1 pc.)
Perforated back wall (1 compartment)
Frame 650 mm high for SzS W 5/270K1
Frame 650 mm high for SzS W 5/510K2
Frame 650 mm high for SzS W 5/750K3
Frame 650 mm high for SzS W 5/990K4
Frame 650 mm high for SzS W 5/1235K5





MOBILE PHONE LOCKERS



Lockers are to be mounted on the wall.
Made of 1 mm thick metal sheet.
Each compartment is locked with a separate key with 1-point locking.

*Lockers are painted with all RAL colours.
Delivered lockers are completely assembled.*

	SKU	DIMENSIONS [mm] H x W x D (WEIGHT[kg])	USEFUL COMPARTMENT DIMENSIONS H x W [mm]
	SzS T5/440K2	780 x 440 x 220	127 x 172
	SzS T4/863K4	780 x 863 x 220	127 x 172
	SzS T5/1499K7	780 x 1499 x 220	127 x 172

UTILITY LOCKERS			
	<p>Welded structure of utility lockers,</p> <ul style="list-style-type: none"> - specially designed double door guarantee high stiffness, - doors provided with vents and a place for an identifier, - side walls of the lockers are provided with openings to couple the lockers with screws, - doors locked with a key-lock with three-point locking. <p><i>Lockers painted with all RAL colours.</i></p> <p><i>Delivered lockers are completely assembled.</i></p>		
	SKU	DIMENSIONS [mm] H x W x D (WEIGHT [kg])	ADDITIONAL DESCRIPTION
	SzG 600/8	1800 x 600 x 490 (42)	4 permanently fixed shelves
	SzG 800/8	1800 x 800 x 490 (49)	
	SzG 600/0	1800 x 600 x 490 (36)	<ul style="list-style-type: none"> - a locker provided with fragmentary partition and 4 permanently fixed shelves, - a holder for cleaning equipment, - a rail with two plastic hooks
	SzG 800/0	1800 x 800 x 490 (42)	
	SzG 600/9	1800 x 600 x 490 (37)	partition divides the locker into two compartments: the left one is provided with 4 permanently fixed shelves, whereas the right one is provided with 1 permanently fixed shelf and a rail with hooks
	SzG 800/9	1800 x 800 x 490 (43)	

LOCKING SYSTEMS AVAILABLE IN UTILITY LOCKERS:

Double-key lock without Master key

Double-key lock with Master key

Locking mechanism for padlock

ADDITIONAL EQUIPMENT OPTIONS AVAILABLE IN UTILITY LOCKERS:

Levelling feet (4 pcs.)

Stands 100 mm high (4 pcs.)

Numbering sticker (1 pc.)

Metal numbering (1 pc.)

Door stop (1 pc.)

Mirror (1 pc.)

ROOFS INCLINED AT 30 DEGREES

Roof inclined at 30 degrees is an optional element to be used with all types of clothing, compartment and utility lockers.



The whole roof is made of metal plate and coated with powder paint. The roof is assembled on the locker top to keep the furniture clean.

Roofs can be painted with any RAL colour.

Our products are covered by 24-months warranty.

SKU	DIMENSIONS [mm] H x W x D (WEIGHT [kg])	TAILORED TO THE FOLLOWING TYPES OF FURNITURE
DSZ 300	282 X 300 X 490 (3)	SzU "L" type 300 wide
DSZ 315	282 X 315 X 490 (3)	SzS, SzU 315 wide
DSZ 400	282 X 400 X 490 (4)	SzU "L" type 400 wide
DSZ 415	282 X 415 X 490 (4)	SzS, SzU 415 wide
DSZ 600	282 X 600 X 490 (6)	SzS, SzU, SzU "L" type, SzG 600 wide
DSZ 800	282 X 800 X 490 (8)	SzS, SzU, SzU "L" type, SzG 800 wide
DSZ 885	282 X 885 X 490 (9)	SzS, SzU 885 wide
DSZ 1175	282 X 1175 X 490 (11)	SzU 1175 wide
DSZ 1185	282 X 1185 X 490 (12)	SzS, SzU 1185 wide

FIXED BENCHES UNDER THE LOCKER



Benches under the locker are installed on the metal frame suitable to place a locker on its top. The said locker is screwed onto the frame.

Benches are available in a number of options and sizes, with different types of panels. Usually benches are provided with MDF panels; still, wooden varnished panels and PVC panels in white and grey colour are available at extra charge.

Benches are provided with levelling feet.

Benches frame can be painted with any RAL colour.

Our products are covered by 24-months warranty.

SKU	DIMENSIONS [mm] H x W x D (WEIGHT [kg])	TAILORED TO THE FOLLOWING TYPES OF FURNITURE
ŁAW ST/300	340 X 300 X 800 (6)	SzU "L" type 300 wide
ŁAW ST/315	340 x 315 x 800 (6)	SzS, SzU 315 wide
ŁAW ST/400	340 x 400 x 800 (7)	SzU "L" type 400 wide
ŁAW ST/415	340 x 415 x 800 (8)	SzS, SzU 415 wide
ŁAW ST/600	340 x 600 x 800 (11)	SzS, SzU, SzU "L" type, SzG 600 wide
ŁAW ST/800	340 x 800 x 800 (14)	SzS, SzU, SzU "L" type, SzG 800 wide
ŁAW ST/885	340 x 885 x 800 (16)	SzS, SzU 885 wide
ŁAW ST/1175	340 x 1175 x 800 (21)	SzU 1175 wide
ŁAW ST/1185	340 x 1185 x 800 (22)	SzS, SzU 1185 wide

FIXED BENCHES UNDER THE LOCKER, WITH SHOE SHELF



Benches under the locker are installed on the metal frame suitable to place a locker on its top.

The said locker is screwed onto the frame.

Shoe shelf with perforated bottom is fixed to the frame.

Benches are available in a number of options and sizes, with different types of panels. Usually benches are provided with MDF panels; still, wooden varnished panels and PVC panels in white and grey colour are available at extra charge.

Benches are provided with levelling feet.

Benches frame can be painted with any RAL colour.

Our products are cover with 24-months guarantee.

SKU	DIMENSIONS [mm] H x W x D (WEIGHT [kg])	TAILORED TO THE FOLLOWING TYPES OF FURNITURE
ŁAW ST/300P	340 X 300 X 800 (8)	SzU "L" type 300 wide
ŁAW ST/315P	340 x 315 x 800 (8)	SzS, SzU 315 wide
ŁAW ST/400P	340 x 400 x 800 (9)	SzU "L" type 400 wide
ŁAW ST/415P	340 x 415 x 800 (9)	SzS, SzU 415 wide
ŁAW ST/600P	340 x 600 x 800 (13)	SzS, SzU, SzU "L" type, SzG 600 wide
ŁAW ST/800P	340 x 800 x 800 (16)	SzS, SzU, SzU "L" type, SzG 800 wide
ŁAW ST/885P	340 x 885 x 800 (17)	SzS, SzU 885 wide
ŁAW ST/1175P	340 x 1175 x 800 (24)	SzU 1175
ŁAW ST/1185P	340 x 1185 x 800 (25)	SzS, SzU 1185 wide

RETRACTABLE BENCHES UNDER THE LOCKER



Retractable benches under the locker comprise two elements:
 - metal frame suitable to place a locker on its top. The said locker is screwed onto the frame.
 - retractable frame provided with a bench.

Benches are available in a number of options and sizes, with different types of panels: usually benches are provided with MDF panels; still, wooden varnished panels and PVC panels in white and grey colour are available at extra charge.

Benches are provided with levelling feet.

Benches frame can be painted with any RAL colour.

Our products are covered by 24-months warranty.

SKU	DIMENSIONS [mm] H x W x D (WEIGHT [kg])	TAILORED TO THE FOLLOWING TYPES OF FURNITURE
ŁAW WS/300	340 X 300 X 800 (9)	SzU "L" type 300 wide
ŁAW WS/315	340 x 315 x 800 (10)	SzS, SzU 315 wide
ŁAW WS/400	340 x 400 x 800 (12)	SzU "L" type 400 wide
ŁAW WS/415	340 x 415 x 800 (10)	SzS, SzU 415 wide
ŁAW WS/600	340 x 600 x 800 (18)	SzS, SzU, SzU "L" type, SzG 600 wide
ŁAW WS/800	340 x 800 x 800 (24)	SzS, SzU, SzU "L" type, SzG 800 wide
ŁAW WS/885	340 x 885 x 800 (26)	SzS, SzU 885 wide
ŁAW WS/1175	340 x 1175 x 800 (35)	SzU 1175 wide
ŁAW WS/1185	340 x 1185 x 800 (36)	SzS, SzU 1185 wide

RETRACTABLE BENCHES UNDER THE LOCKER, WITH SHOE SHELF



- Retractable benches under the locker comprise two elements:
- metal frame suitable to place a locker on its top. The said locker is screwed onto the frame.
 - retractable frame provided with a bench and shoe shelf with perforated bottom.

Benches are available in a number of options and sizes, with different types of panels: usually benches are provided with MDF panels; still, wooden varnished panels and PVC panels in white and grey colour are available at extra charge.

Benches are provided with levelling feet.

Benches frame can be painted with any RAL colour.

Our products are covered by 24-months warranty.

SKU	DIMENSIONS [mm] H x W x D (WEIGHT [kg])	TAILORED TO THE FOLLOWING TYPES OF FURNITURE
ŁAW WS/300P	340 X 300 X 800 (11)	SzU "L" type 300 wide
ŁAW WS/315P	340 x 315 x 800 (11)	SzS, SzU 315 wide
ŁAW WS/400P	340 x 400 x 800 (14)	SzU "L" type 400 wide
ŁAW WS/415P	340 x 415 x 800 (15)	SzS, SzU 415 wide
ŁAW WS/600P	340 x 600 x 800 (20)	SzS, SzU, SzU "L" type, SzG 600 wide
ŁAW WS/800P	340 x 800 x 800 (26)	SzS, SzU, SzU "L" type, SzG 800 wide
ŁAW WS/885P	340 x 885 x 800 (38)	SzS, SzU 885 wide
ŁAW WS/1175P	340 x 1175 x 800 (38)	SzU 1175 wide
ŁAW WS/1185P	340 x 1185 x 800 (39)	SzS, SzU 1185 wide

RETRACTABLE BENCHES UNDER THE LOCKER, WITH 2 LOCKERS



- Retractable benches under the locker, with 2 lockers, comprise two elements:
- metal frame suitable to place a locker on its top. The said locker is screwed onto the frame.
 - retractable frame provided with a bench, to which 2 separately locked shoe lockers with full hinged doors are fixed. Each door is locked with a key-lock.

Benches are available in a number of options and sizes, with different types of panels: usually benches are provided with MDF panels; still, wooden varnished panels and PVC panels in white and grey colour are available at extra charge.

Benches are provided with levelling feet.

Benches frame can be painted with any RAL colour.

Our products are covered by 24-months warranty.

SKU	DIMENSIONS [mm] H x W x D (WEIGHT [kg])	TAILORED TO THE FOLLOWING TYPES OF FURNITURE
ŁAW WS/600B	340 x 600 x 800 (25)	SzS, SzU, SzU "L" type, SzG 600 wide
ŁAW WS/800B	340 x 800 x 800 (30)	SzS, SzU, SzU "L" type, SzG 800 wide

PANELS AVAILABLE IN FIXED AND RETRACTABLE BENCHES

MDF panels

Pinewood varnished panels

PVC panels in white or grey colour

BENCHES FOR OTHER TYPES OF LOCKERS ARE CUSTOM MADE TO ORDER.

BENCH-HEIGHT PLATFORMS UNDER THE LOCKER (new in 2018)



A platform lacking seat to be placed under a locker is made of full steel profiles suitable to place on it a locker. The said locker is screwed onto the platform frame

Platforms are provided with levelling feet.

Platform frame can be painted with any RAL colour.

Our products are covered by 24-months warranty.

SKU	DIMENSIONS [mm] H x W x D (WEIGHT [kg])	TAILORED TO THE FOLLOWING TYPES OF FURNITURE
ŁAW PS/300	340 x 300 x 800 (6)	SzU 'L' type 300 wide
ŁAW PS/315	340 x 315 x 800 (6)	SzS, SzU 315 wide
ŁAW PS/400	340 x 400 x 800 (7)	SzU 'L' type 400 wide
ŁAW PS/415	340 x 415 x 800 (8)	SzS, SzU 415 wide
ŁAW PS/600	340 x 600 x 800 (11)	SzS, SzU, SzU 'L' type, SzG 600 wide
ŁAW PS/800	340 x 800 x 800 (14)	SzS, SzU, SzU 'L' type, SzG 800 wide
ŁAW PS/885	340 x 885 x 800 (16)	SzS, SzU 885 wide
ŁAW PS/1175	340 x 1175 x 800 (21)	SzU 1175 wide
ŁAW PS/1185	340 x 1185 x 800 (22)	SzS, SzU 1185 wide

BENCH-HEIGHT PLATFORMS UNDER THE LOCKER, WITH SHOE SHELF (new in 2018)



A platform lacking seat to be placed under a locker is made of full steel profiles suitable to place on it a locker provided with a shoe shelf having perforated bottom. The said locker is screwed onto the platform frame. Shoe shelf with perforated bottom is screwed onto the frame.

Platforms are provided with levelling feet.

Platform frame can be painted with any RAL colour.

Our products are covered by 24-months warranty.

SKU	DIMENSIONS [mm] H x W x D (WEIGHT [kg])	TAILORED TO THE FOLLOWING TYPES OF FURNITURE
ŁAW PSP/300	340 x 300 x 800 (6)	SzU „L” type 300 wide
ŁAW PSP/315	340 x 315 x 800 (6)	SzS, SzU 315 wide
ŁAW PSP/400	340 x 400 x 800 (7)	SzU ‘L’ type 400 wide
ŁAW PSP/415	340 x 415 x 800 (8)	SzS, SzU 415 wide
ŁAW PSP/600	340 x 600 x 800 (11)	SzS, SzU, SzU ‘L’ type SzG 600 wide
ŁAW PSP/800	340 x 800 x 800 (14)	SzS, SzU, SzU ‘L’ type, SzG 800 wide
ŁAW PSP/885	340 x 885 x 800 (16)	SzS, SzU 885 wide
ŁAW PSP/1175	340 x 1175 x 800 (21)	SzU 1175 wide
ŁAW PSP/1185	340 x 1185 x 800 (22)	SzS, SzU 1185 wide

FREE-STANDING BENCHES



Free-standing benches are structured on the square metal frame coated with powder paint.

Benches are available in a number of options and sizes, with different types of panels: usually benches are provided with MDF panels; still, wooden varnished panels and plastic panels in grey or white colour are available at extra charge.

Benches are provided with levelling feet.

Benches frame can be painted with any RAL colour.

Our products are covered by 24-months warranty.

SKU	DIMENSIONS [mm] H x W x D (WEIGHT [kg])
ŁAW WL/600	400 x 600 x 400 (5)
ŁAW WL/900	400 x 900 x 400 (8)
ŁAW WL/1200	400 x 1200 x 400 (10)
ŁAW WL/1400	400 x 1400 x 400 (12)
ŁAW WL/1500	400 x 1500 x 400 (12)
ŁAW WL/1600	400 x 1600 x 400 (13)
ŁAW WL/1800	400 x 1800 x 400 (15)
ŁAW WL/2000	400 x 2000 x 400 (17)

FREE-STANDING BENCHES, WITH SHOE SHELF

Free-standing benches are structured on the square metal frame coated with powder paint.

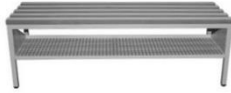

Shoe shelf with perforated bottom is fixed to the frame.

Benches are available in a number of options and sizes, with different types of panels: usually benches are provided with MDF panels; still, wooden varnished panels and plastic panels in grey or white colour are available at extra charge.

Benches are provided with levelling feet.

Benches frame can be painted with any RAL colour.

Our products are covered by 24-months warranty.

SKU	DIMENSIONS [mm] H x W x D (WEIGHT [kg])
ŁAW WL/600P	400 x 600 x 400 (6)
ŁAW WL/900P	400 x 900 x 400 (8)
ŁAW WL/1200P	400 x 1200 x 400 (10)
ŁAW WL/1400P	400 x 1400 x 400 (12)
ŁAW WL/1500P	400 x 1500 x 400 (13)
ŁAW WL/1600P	400 x 1600 x 400 (14)
ŁAW WL/1800P	400 x 1800 x 400 (15)
ŁAW WL/2000P	400 x 2000 x 400 (17)

PANELS AVAILABLE IN FREE-STANDING BENCHES

MDF panels

Pinewood varnished panels

PVC panels in white or grey colour

BENCHES WITH COAT RACKS



Benches with coat racks are constructed on the reinforced frame of 25 mm x 25 mm profile.

Usually this furniture is provided with durable pinewood varnished panels:

- which are 50 mm wide and 20 mm high (applies to ŁAW WO and LAW WOP),
- which are 90 mm wide and 20 mm high (applies to ŁAW WOS)

Optionally benches can be provided with beechwood panels coated with transparent varnish or PVC panels in white or grey colour.

Benches are provided with levelling feet.

Frame in the bench with coat rack can be painted with any RAL colour.

Delivered benches with coat racks are completely assembled.

Our products are covered by 24-months warranty.

	SKU	DIMENSIONS [mm] H x W x D (WEIGHT [kg])	ADDITIONAL DESCRIPTION
No shelf			
	ŁAW WO/1650 X 1000	1650 X 1000 X 403 (17)	<p>Frame is provided with the following fixed elements:</p> <ul style="list-style-type: none"> - 2 pinewood panels, - bench with 5 panels, - 6 single metal hooks (in benches 1000 wide), - 8 single metal hooks (in benches 1500 wide), - 10 single metal hooks (in benches 2000 wide) <p>The frame is provided with openings to couple back of 2 benches with screws.</p>
	ŁAW WO/1650 X 1500	1650 X 1500 X 403 (23)	
	ŁAW WO/1650 X 2000	1650 X 2000 X 403 (35)	
With a shelf			
	ŁAW WOP/1750 X 1000	1750 X 1000 X 403 (19)	<p>Frame is provided with the following fixed elements:</p> <ul style="list-style-type: none"> - 2 panels forming a back rest, - bench with 5 panels, - a shelf with metal profiles <p>Elements permanently welded to the frame:</p> <ul style="list-style-type: none"> - 6 single metal hooks (in benches 1000 wide), - 8 single metal hooks (in benches 1500 wide), - 10 single metal hooks (in benches 2000 wide)
	ŁAW WOP/1750 X 1500	1750 X 1500 X 403 (30)	

	ŁAW WOP/1750 X 2000	1750 X 2000 X 403 (40)	The frame is provided with openings to couple back of 2 benches with screws.
School			
	ŁAW WOS/1200	1200 X 1200 X 325 (15)	<p>Frame is provided with the following fixed elements:</p> <ul style="list-style-type: none"> - upper panel onto which 6 double metal hooks are screwed, - single panel forming a back rest, - bench with 3 panels, <p>The frame is provided with openings to couple back of 2 benches with screws. Moreover, additional plates are provided to fasten the furniture to the base surface or the wall.</p>
	ŁAW WOS/1650	1650 X 1200 X 430 (24)	<p>Frame is provided with the following fixed elements:</p> <ul style="list-style-type: none"> - upper panel onto which 8 double metal hooks are screwed, - single panel forming a back rest, - bench with 4 panels, <p>The frame is provided with openings to couple back of 2 benches with screws. Moreover, additional plates are provided to fasten the furniture to the base surface or the wall.</p>

PANELS AVAILABLE IN BENCHES WITH COAT RACKS





Pinewood varnished panels

PVC panels



Beechwood panels

ADDITIONAL EQUIPMENT OPTIONS

Anchors to fasten the bench to the base surface (concerns ŁAW/WO and ŁAW/WOP)

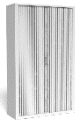
HIGH OFFICE CABINETS				
 <p>Hinged doors are provided with reinforced inner profile, - doors are provided with internal hinges, giving free access to the furniture interior, - doors are locked with a key lock with a hand wheel, with 3-point locking system</p> <p><i>Cabinets painted with all RAL colours. Delivered cabinets are completely assembled, still shelves need to be mounted.</i></p>				
	SKU	DIMENSIONS [mm] H x W x D (WEIGHT [kg])	ADDITIONAL DESCRIPTION	
No door				
	SZA 00800/400	2000 x 800 x 420 (37)	The cabinet is provided with 4 adjustable shelves. Perforated profiles inside the cabinet are provided to adjust the shelf height every 25 mm.	
	SZA 001000/400	2000 X 1000 X 420 (42)		
	SZA 001200/400	2000 X 1200 X 420 (48)		
1- door				
	SZA 1D1000/400	2000 x 500 x 420 (36)	provided with 4 adjustable shelves. Perforated profiles inside the cabinet are provided to adjust the shelf height every 25 mm.	
2- doors				
With hinged doors.		SZA 2D800/400	2000 x 800 x 420 (51)	The cabinet is provided with 4 adjustable shelves. Perforated profiles inside the cabinet are provided to adjust the shelf height every 25 mm.
		SZA 2D1000/400	2000 X 1000 X 420 (59)	
		SZA 2D1200/400	2000 X 1200 X 420 (68)	
		SZA 2D800/312	2000 x 800 x 420 (56)	The cabinet is provided with 3 adjustable shelves and a permanently fixed locker with 2 compartments. Each compartment is separately locked with a key-lock. Perforated profiles inside the cabinet are provided to adjust the shelf height every 25 mm.
		SZA 2D1000/312	2000 X 1000 X 420 (67)	
		SZA 2D1200/312	2000 X 1200 X 420 (73)	

With sliding doors		SZA DS1000/400	2000 X 1000 X 420 (63)	The cabinet is provided with 4 adjustable shelves. Perforated profiles inside the cabinet are provided to adjust the shelf height every 25 mm. Sliding doors are provided with flush handle.
		SZA DS1200/400	2000 X 1200 X 420 (72)	
With roller shutter doors		SZA ZZ1000/400	2000 X 1000 X 420 (62)	Double shutter doors made of PVC, drawing aside. When open, the doors are completely concealed along the side walls of the cabinet, giving unlimited access to the interior. Doors are locked with a key-lock. The cabinet is provided with 4 adjustable shelves. Perforated profiles inside the cabinet are provided to adjust the shelf height every 25 mm.
		SZA ZZ1200/400	2000 X 1200 X 420 (71)	

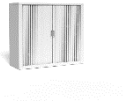
LOW OFFICE CABINETS			
	<p>Hinged doors are provided with reinforced inner profile, - doors are provided with internal hinges, giving free access to the furniture interior, - doors are locked with a key lock with a hand wheel, with 3-point locking system</p> <p><i>Cabinets painted with all RAL colours. Delivered cabinets are completely assembled, still shelves need to be mounted.</i></p>		
	SKU	DIMENSIONS [mm] H x W x D (WEIGHT [kg])	ADDITIONAL DESCRIPTION
With hinged doors.			
	SZA 2D800/200	1050 x 800 x 420 (39)	<p>The cabinet is provided with 2 adjustable shelves. Perforated profiles inside the cabinet are provided to adjust the shelf height every 25 mm.</p>
	SZA 2D1000/200	1050 x 1000 x 420 (45)	
	SZA 2D1200/200	1050 x 1200 x 420 (52)	
With roller shutter doors			
	SZA 2Z1200/1200_105 0	1050 x 1200 x 450 (42)	<p>Double shutter doors made of PVC, drawing aside. When open, the doors are completely concealed along the side walls of the cabinet, giving unlimited access to the interior. Doors are locked with a key-lock. The cabinet is provided with 2 adjustable shelves. Perforated profiles inside the cabinet are provided to adjust the shelf height every 25 mm.</p>

OFFICE AND CLOTHING CABINET



Office and clothing cabinet with hinged doors is divided into two sections:

1. section for office purposes is provided with 4 adjustable shelves. Perforated profiles inside the cabinet are provided to adjust the shelf height every 25 mm.
2. section for clothing purposes is provided with 1 permanently fixed shelf and a rail with coat hooks.
 - hinged doors are provided with reinforced inner profile,
 - doors are provided with internal hinges, giving free access to the furniture interior,
 - doors are locked with a key lock with a hand wheel, with 3-point locking system.

Cabinets painted with all RAL colours.

Delivered cabinets are completely assembled, still shelves need to be mounted.

SKU	DIMENSIONS [mm] H x W x D (WEIGHT [kg])	ADDITIONAL DESCRIPTION
SZA 2D1000/4U00	2000 x 1000 x 420 (57)	

DOUBLE OFFICE CABINET



Double office cabinet with double door:

- provided with 1 permanently fixed shelf having the width of the cabinet,
- below the fixed shelf there is a partition dividing the cabinet into two sections, each of which is provided with 4 adjustable shelves. Perforated profiles inside the cabinet are provided to adjust the shelves height every 25 mm.
 - hinged doors are provided with reinforced inner profile,
- doors are provided with internal hinges, giving free access to the furniture interior,
- doors are locked with a key lock with a hand wheel, with 3-point locking system.

Cabinets painted with all RAL colours.

Delivered cabinets are completely assembled, still shelves need to be mounted.

SKU	DIMENSIONS [mm] H x W x D (WEIGHT [kg])	ADDITIONAL DESCRIPTION
SZA 2D1000/8A00	2000 x 1000 x 420 (62)	

DOUBLE CLOTHING CABINET



Double clothing cabinet with double door:

- provided with 1 permanently fixed shelf having the width of the cabinet,
- below the fixed shelf there is a partition dividing the cabinet into two sections, each of which is provided with a rail and a coat hook,
- hinged doors are provided with reinforced inner profile,
- doors are provided with internal hinges, giving free access to the furniture interior,
- doors are locked with a key lock with a hand wheel, with 3-point locking system.

Cabinets painted with all RAL colours.

Delivered cabinets are completely assembled.

SKU	DIMENSIONS [mm] H x W x D (WEIGHT [kg])	ADDITIONAL DESCRIPTION
SZA 2D1000/2U00	2000 x 1000 x 420 (52)	

OFFICE AND FILE CABINETS



Office and file cabinets are divided into two sections:

1. in the top part of the office cabinet there are adjustable shelves, where 3 rows of A3 file binders can be placed. Perforated profiles located in the middle of this section are provided to adjust the shelves height every 25 mm.

Hinged doors in the office section have inner reinforcement profile; the doors are locked with a key lock with a hand wheel, with 3-point locking system.

Doors are provided with internal hinges, giving free access to the furniture interior,

2. bottom section of the cabinet provided with file drawers.

This section of the cabinet is provided with a special mechanism, so that only one drawer can be open at a time, which consequently prevents the cabinet from falling down.

Drawers are mounted on the telescopic ball slides with a stop, which prevents the drawer from falling out of the cabinet. Maximum load for each drawer is 50 kg.



Each drawer has a place for an identifier.

Drawers are locked with a single master lock, which locks them simultaneously.

Cabinets painted with all RAL colours.

Delivered cabinet is completely assembled, still shelves need to be mounted.

SKU	DIMENSION S [mm] H x W x D (WEIGHT [kg])	ADDITIONAL DESCRIPTION

with 3 drawers		SzAK 3_1000	2000 X 1000 X 420 (90)	<p>In the top section of the office cabinet there are 2 adjustable shelves, where 3 rows of A3 file binders can be placed.</p> <p>Bottom section of the cabinet is provided with 2 drawers for horizontal storing of A4 files or suspension files and 1 shallow drawer 215 mm high) for storing other office supplies.</p>
		SzAK 3_1200	2000 X 1200 X 420 (93)	
with 4 drawers		SzAK 4_1000	2000 X 1000 X 420 (95)	<p>In the top section of the office cabinet there is 1 adjustable shelf.</p> <p>Bottom section of the cabinet is provided with 4 drawers for horizontal storing of A4 files or suspension files or other office supplies.</p>
		SzAK 4_1200	2000 x 1200 x 420 (98)	

ADDITIONAL EQUIPMENT OPTIONS AVAILABLE IN OFFICE CABINETS, OFFICE AND CLOTHING CABINETS, DOUBLE OFFICE CABINETS, AND OFFICE AND FILES CABINETS

UV printing on the hinged door (1 pc of printing)

Levelling feet (4 pcs.)



Additional shelf with adjustable height

HEIGHT EXTENSION UNITS FOR OFFICE CABINETS, DOUBLE OFFICE CABINETS, OFFICE AND CLOTHING CABINETS, AND OFFICE AND FILES CABINETS



Height extension units painted with all RAL colours.
Delivered height extension units are completely assembled, still shelves need to be mounted.





		SKU	DIMENSIONS [mm] H x W x D (WEIGHT [kg])	ADDITIONAL DESCRIPTION
With hinged doors		SZN 2D465/800/1	465 x 800 x 420 (14)	<p>Perforated profiles inside the height extension units are provided to adjust the shelf height every 25 mm.</p> <ul style="list-style-type: none"> - includes 1 shelf, - doors are provided with internal hinges, giving free access to the height extension unit interior, - doors are locked with a key lock with a hand wheel, with 3-point locking system. <p>Bottom wall of the height extension unit is provided with openings to screw the unit onto the cabinet (screws not included).</p>
		SZN 2D465/1000/1	465 x 1000 x 420 (18)	
		SZN 2D465/1200/1	465 X 1200 X 420 (22)	
		SZN 2D800/800/1	800 x 800 x 420 (26)	
		SZN 2D800/1000/1	800 X 1000 X 420 (31)	
		SZN 2D800/1200/1	800 x 1200 x 420 (37)	







With sliding doors		SZN DS465/1000/1	465 X 1000 X 420 (19)	<p>Perforated profiles inside the height extension units are provided to adjust the shelf height every 25 mm. - includes 1 shelf, - metal sliding doors are provided with flush handles, - doors are locked with a key lock, with 1-point locking system</p> <p>Bottom wall of the height extension unit is provided with openings to screw the unit onto the cabinet (screws not included).</p>
		SZN DS465/1200/1	465 X 1200 X 420 (24)	
		SZN DS800/1000/1	800 x 1000 x 420 (33)	
		SZN DS800/1200/1	800 x 1200 x 420 (39)	





ADDITIONAL EQUIPMENT OPTIONS IN HEIGHT EXTENSION UNITS

UV printing on the hinged door (1 pc of printing)

Additional shelf with adjustable height

FILE CABINETS			
	<p>File cabinets are provided with a special mechanism, so that only one drawer can be open at a time, which consequently prevents the cabinet from falling down.</p> <ul style="list-style-type: none"> - drawers are mounted on the fully extendible telescopic ball slides with a stop, which prevents the drawer from falling out of the cabinet. Maximum load for each drawer is 50 kg. Drawers with higher load bearing capacity can be optionally custom made. - each drawer has a place for an identifier. <p>Cabinets are locked with a single master lock, which locks all drawers simultaneously.</p> <p style="text-align: center;"><i>Cabinets painted with all RAL colours. Delivered cabinets are completely assembled, still shelves need to be mounted.</i></p>		
	SKU	DIMENSIONS [mm] H x W x D (WEIGHT [kg])	ADDITIONAL DESCRIPTION
For A4			
	SSK 2/01A4	715 x 415 x 630 (19)	For horizontal storing of A4 files or suspension files. Number of rows per drawer: 1
	SSK 2/02A4	715 X 775 X 630 (33)	For horizontal storing of A4 files or suspension files. Each drawer is provided with a partition. Number of rows per drawer: 2
	SSK 3/01A4	1000 X 415 X 630 (35)	3 drawers designed for horizontal storing of A4 files or suspension files. Number of rows per drawer: 1
	SSK 4/01A4	1285 X 415 X 630 (38)	For horizontal storing of A4 files or suspension files. Number of rows per drawer: 1

	SSK 4/02A4	1285 X 775 X 630 (64)	For horizontal storing of A4 files or suspension files. Each drawer is provided with a partition. Number of rows per drawer: 2
	SSK 5/01A4	1568 X 415 X 630 (42)	5 drawers designed for horizontal storing of B5 documents (personal holders). Each drawer is provided with a partition. Number of rows per drawer: 1
For A5			
	SSK 5/02A5	1285 x 545 x 630 (52)	For horizontal storing of A5 documents. Each drawer is provided with a partition. Number of rows per drawer: 2
For A6			
	SSK 8/04A6	1285 X 775 X 630 (61)	For horizontal storing of A6 files in four rows. Maximum size of the stored document is 130 mm x 168 mm. Each drawer is provided with 4 partitions. Number of rows per drawer: 4.
For B5			
	SSK 2/02B5	600 x 610 x 630 (18)	Designed for horizontal storing of B5 documents (personal holders). Each drawer is provided with a partition. Number of rows per drawer: 2
	SSK 3/02B5	830 x 610 x 630 (26)	3 drawers designed for horizontal storing of B5 documents (personal holders). Each drawer is provided with a partition. Number of rows per drawer: 2

	SSK 4/02B5	1067 x 610 x 630 (45)	4 drawers designed for horizontal storing of B5 documents (personal holders). Each drawer is provided with a partition. Number of rows per drawer: 2
	SSK 5/01B5	1285 x 345 x 630 (41)	5 drawers designed for horizontal storing of B5 documents. Number of rows per drawer: 1
	SSK 5/02B5	1285 X 610 X 630 (58)	5 drawers designed for horizontal storing of B5 documents. Each drawer is provided with a partition. Number of rows per drawer: 2
	SSK 6/02B5	1514 X 610 X 630 (63)	6 drawers designed for horizontal storing of B5 documents. Each drawer is provided with 1 partition. Number of rows per drawer: 4

For passport applications			
	SSK 03/04KP	731 x 532 x 630	Each drawer is suitable for storing passport applications of max. size 180 x 105 mm. Number of rows per drawer: 4

MAP AND PLAN CABINETS











Map and plan cabinets are provided with a special mechanism, so that only one drawer can be open at a time, which consequently prevents the cabinet from falling down.
- drawers are mounted on the fully extendible telescopic ball slides with a stop, which prevents the drawer from falling out of the cabinet. Maximum load for each drawer is approx. 50 kg. Drawers with higher load bearing capacity can be optionally custom made.

Cabinets are locked with a single master lock, which locks all drawers simultaneously.

Cabinets painted with all RAL colours.

Delivered cabinets are completely assembled, still shelves need to be mounted.

	SKU	DIMENSIONS [mm] H x W x D (WEIGHT [kg])	ADDITIONAL DESCRIPTION	
For A0				
	SSK 5/01A0 _445	445 X 1338 X 1005 (124)	5 drawers for horizontal storing of maps and plans in A0 size	Internal dimensions of drawers: 1249 mm W x 900 mm D x 55 mm H
	SSK 5/01A0 _545	545 X 1338 X 1005 (128)		Internal dimensions of drawers: 1249 mm W x 900 mm D x 75 mm H
	SSK 6/01A0 _505	505 X 1338 X 1005 (135)	6 drawers for horizontal storing of maps and plans in A0 size	Internal dimensions of drawers: 1249 mm W x 900 mm D x 55 mm H
	SSK 6/01A0 _625	625 X 1338 X 1005 (139)		Internal dimensions of drawers: 1249 mm W x 900 mm D x 75 mm H
	SSK 10/01A 0_745	745 X 1338 X 1005 (224)	10 drawers for horizontal storing of maps and plans in A0 size	Internal dimensions of drawers: 1249 mm W x 900 mm D x 55 mm H
	SSK 10/01A 0_945	945 X 1338 X 1005 (235)		Internal dimensions of drawers: 1249 mm W x 900 mm D x 75 mm H
	SSK 3/01A1 _325	325 X 970 X 720 (57)	3 drawers for horizontal storing of maps and plans in A1 size	Internal dimensions of drawers: 880 mm W x 616 mm D x 55 mm H

	SSK 5/01A1 _445	445 X 970 X 720 (69)	5 drawers for horizontal storing of maps and plans in A1 size	
	SSK 10/01A 1_745	745 X 970 X 720 (146)	10 drawers for horizontal storing of maps and plans in A1 size	
For B1				
	SSK 5/01B1 _545	545 X 1147 X 872 (112)	5 drawers for horizontal storing of maps, plans and technical documentation in B1 size	Internal dimensions of drawers: 75 mm H x 1057 mm W x 768 mm D
	SSK 6/01B1 _625	625 X 1147 X 872 (121)	6 drawers for horizontal storing of maps, plans and technical documentation in B1 size	
	SSK 7/01B1 _705	705 X 1147 X 872 (132)	7 drawers for horizontal storing of maps, plans and technical documentation in B1 size	

ADDITIONAL EQUIPMENT OPTIONS AVAILABLE IN FILE CABINETS AND MAP AND PLAN CABINETS

Levelling feet (4 pcs.)

Base unit 100 mm high

DESKS

Frames in the desks and additional units are made of full steel profiles with quadrangle cross-section, and are provided with levelling feet.



Table-tops are 25 mm thick and are laminated in grey colour.

Completely metal containers are provided with drawers, front side of which have flush handles. Drawers with safe edges are mounted on solid telescopic ball slides with a special mechanism, so that only one drawer can be open at a time; they are locked with a master lock.

Types of containers:



- 2-drawer container (02) for the table-top of: [H x W x D] 514 mm x 407 mm x 778 mm. Top drawer with the following useful dimensions: [H x W x D] 135 mm x 327 mm x 700 mm and extension of 500 mm, bottom drawer for suspension files with the following useful dimensions: [H x W x D] 280 mm x 327 mm x 718 mm and extension of 500 mm.
- 2-drawer container (02) for additional unit of: [H x W x D] 514 mm x 407 mm x 578 mm. Top drawer of the following useful dimensions: [H x W x D] 135 mm x 327 mm x 500 mm, bottom drawer for suspension files with the following useful dimensions: [H x W x D] 280 mm x 327 mm x 518 mm and extension of 500 mm.
- 3-drawer container (03) for the table-top of: [H x W x D] 514 mm x 407 mm x 778 mm. 3 drawers with the following useful dimensions: [H x W x D] each of 135 mm x 327 mm x 718 mm and extension of 500 mm. Drawers in the container are locked with a key-lock.
- 3-drawer container (03) for additional unit of: [H x W x D] 514 mm x 407 mm x 578 mm. 3 drawers with the following useful dimensions: [H x W x D] each of 135 mm x 327 mm x 500 mm. Drawers in the container are locked with a key-lock.







Table and additional units are delivered in parts and need to be assembled.







Delivered containers are completely assembled, still they need to be screwed to the table or additional unit frame.



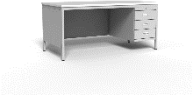



Frame in the tables, additional units and containers can be painted with any RAL colour.









	SKU	DIMENSIONS [mm] H x W x D	ADDITIONAL DESCRIPTION (WEIGHT [kg])
STRAIGHT DESK			
	BP 00/00/ OSO	740 x 1600 x 800	No walls (32)









	BP 00/00/ OS1		With back wall (35)
	BP 00/00/ OS3		With back and side walls (39)



STRAIGHT DESK WITH 1 METAL CONTAINER ON THE LEFT			
	BP/L 02/00/ OS0	740 x 1600 x 800	- container with 2 drawers, - no walls (70)
	BP/L 03/00/ OS0		- container with 3 drawers, - no walls (77)
	BP/L 02/00/ OS2		- container with 2 drawers, - with back and side wall (77)
	BP/L 03/00/ OS2		- container with 3 drawers, - with back and side wall (84)
STRAIGHT DESK WITH 1 METAL CONTAINER ON THE RIGHT			
	BP/P 00/02/ OS0	740 x 1600 x 800	- container with 2 drawers, - no walls (70)
	BP/P 00/03/ OS0		- container with 3 drawers, - no walls (77)





	BP/P 00/02/ OS2		- container with 2 drawers, - with back and side wall (77)
	BP/P 00/03/ OS2		- container with 3 drawers, - with back and side wall (84)
STRAIGHT DESK WITH 2 CONTAINERS			
	BP/LP 02/02/ OS0	740 x 1600 x 800	- 2 containers with 2 drawers - no wall (108)
	BP/LP 02/03/ OS0		- 1 container with 2 drawers - 1 container with 3 drawers - no wall (115)
	BP/LP 03/02/ OS0		- 1 container with 2 drawers - 1 container with 3 drawers - no wall (115)
	BP/LP 03/03/ OS0		- 2 containers with 3 drawers - no wall (122)
	BP/LP 02/02/ OS1		- 2 containers with 2 drawers - with back wall (112)
	BP/LP 02/03/ OS1		- 1 container with 2 drawers - 1 container with 3 drawers - with back wall (119)

	BP/LP 03/02/ OS1		- 1 container with 2 drawers - 1 container with 3 drawers - with back wall (119)
	BP/LP 03/03/ OS1		- 2 containers with 3 drawers - with back wall (126)
DESK WITH ADDITIONAL UNIT (BD) ON THE LEFT			
	BD/L 00/00/ OS0		- no wall (60)
	BD/L 00/00/ OS2	Desk dimensions: 740 x 1600 x 800 Container dimensions: 650 x 1200 x 600	- with back walls (67)
	BD/L 00/00/ OS4		- with back and side walls (75)
DESK WITH ADDITIONAL UNIT ON THE RIGHT			
	BD/P 00/00/ OS0		- no wall (60)
	BD/P 00/00/ OS2	Desk dimensions: 740 x 1600 x 800 Container dimensions: 650 x 1200 x 600	- with back walls (67)
	BD/P 00/00/ OS4		- with back and side walls (75)
DESK WITH ADDITIONAL UNIT COMPRISING 1 CONTAINER ON THE LEFT			

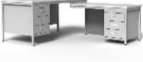
	BD/L 03/00/ OS0	Desk dimensions: 740 x 1600 x 800 Container dimensions: 650 x 1200 x 600	- 1 container with 3 drawers - no walls (99)
	BD/L 03/00/ OS2		- 1 container with 3 drawers - with 2 back walls (106)
DESK WITH 1 CONTAINER AND ADDITIONAL UNIT ON THE LEFT			
	BD/L 00/02/ OS0	Desk dimensions: 740 x 1600 x 800 Container dimensions: 650 x 1200 x 600	- 1 container with 2 drawers - no walls (96)
	BD/L 00/03/ OS0		- 1 container with 3 drawers - no walls (99)
	BD/L 00/02/ OS2		- 1 container with 2 drawers - with 2 back walls (104)
	BD/L 00/03/ OS2		- 1 container with 3 drawers - with 2 back walls (106)
DESK WITH 1 CONTAINER AND ADDITIONAL UNIT COMPRISING 1 CONTAINER ON THE LEFT			
	BD/L 03/02/ OS0	Desk dimensions: 740 x 1600 x 800 Container dimensions: 650 x 1200 x 600	- 1 container with 3 drawers - 1 container with 2 drawers - no walls (144)
	BD/L 03/03/ OS0		- 2 containers with 3 drawers - no walls (144)
	BD/L 03/02/ OS2		- 1 container with 3 drawers - 1 container with 2 drawers - with 2 back walls (152)

	BD/L 03/03/ OS2		- 2 containers with 3 drawers - with 2 back walls (152)
DESK WITH ADDITIONAL UNIT COMPRISING 1 CONTAINER ON THE RIGHT			
	BD/P 00/03/ OS0	Desk dimensions: 740 x 1600 x 800	- 1 container with 3 drawers - no walls (99)
	BD/P/0 0/03/O S2	Container dimensions: 650 x 1200 x 600	- 1 container with 3 drawers - with 2 back walls (104)
DESK WITH 1 CONTAINER AND WITH ADDITIONAL UNIT ON THE RIGHT			
	BD/P 02/00/ OS0		- 1 container with 2 drawers - no walls (96)
	BD/P 03/00/ OS0	Desk dimensions: 740 x 1600 x 800	- 1 container with 3 drawers - no walls (99)
	BD/P 02/00/ OS2	Container dimensions: 650 x 1200 x 600	- 1 container with 2 drawers - with 2 back walls (104)
	BD/P 03/00/ OS2		- 1 container with 3 drawers - with 2 back walls (106)
DESK WITH 1 CONTAINER AND WITH ADDITIONAL UNIT COMPRISING 1 CONTAINER ON THE RIGHT			
	BD/P 02/03/ OS0	Desk dimensions: 740 x 1600 x 800 Container dimensions:	- no walls (144)

	BD/P 03/03/ OS0	650 x 1200 x 600	- no walls (147)
	BD/P 02/03/ OS2		- with 2 back walls (150)
	BD/P 03/03/ OS2		- with 2 back walls (153)

TECHBOX METAL BOXES			
	<p>Massive Techbox boxes are locked with locks certified in "A" class,</p> <ul style="list-style-type: none"> - hydraulic lifts provide easy opening and closing of the massive cover, as well as unrestricted access to the box interior, - the cover completely protects the box interior from external contamination (such as dust, pouring, etc.) - an opening protected by the cover (on the front or back side) used to connect devices stored in the box with the power cable (e.g. when device charging is needed) - openings provided on the side walls for transportation. <p style="text-align: center;"><i>Boxes painted with all RAL colours. Delivered boxes are completely assembled.</i></p>		
	SKU	DIMENSIONS [mm] H x W x D (WEIGHT [kg])	ADDITIONAL DESCRIPTION
	TchB 780	400 x 780 x 450 (26)	1 lock certified in "A" class
	TchB 1168	629 x 1168 x 560 (49)	2 locks certified in "A" class
	TchB 1369	490 x 1369 x 560 (49)	2 locks certified in "A" class

ADDITIONAL EQUIPMENT OPTIONS AVAILABLE IN THE TECHBOXES
Docking station
Metal handles (2 pcs)
4 casters, including 2 casters with brake

RECYCLING BINS



- Welded structure of the bins is made of full profiles,
- doors locked with a lock with optional padlock application,
 - provided with inlet opening with self-closing hinged flap,
 - gasket provided around the opening.
 - openings provided on the back of the bins to fasten them to the wall,
 - each bin is provided with a pictogram sticker (optional)



PSO 1, PSO 2, PSO 3 and PSO 4 bins can be provided with:







- 1W - retractable frame mounted on telescopic slides, onto which bags can be hung Slides can be maximally extended, therefore bags are easily and quickly changed; a cover which is placed on the frame prevents the bags from slipping
- 1P - inside the bin there is a metal basket with handles cut on both sides, which is coated with powder paint in grey colour RAL 7035.





Bins painted with all RAL colours.

Our products are covered by 24-months warranty.

Delivered bins are completely assembled.

	SKU	DIMENSIONS [mm] H x W x D (WEIGHT [kg])	ADDITIONAL DESCRIPTION
1- Compartment			
	PSO 1_1W	1070 x 356 x 350 (14)	1 frame onto which bags are hung
	PSO 1_1P	1070 x 356 x 350 (20)	1 metal basket with handles cut on both sides
2- compartment			
	PSO 2_1P_1W	1070 x 710 x 350 (30)	- 1 frame onto which bags are hung - 1 metal basket with handles cut on both sides

	PSO 2_2W	1070 x 710 x 350 (25)	2 frames onto which bags are hung
	PSO 2_2P	1070 x 710 x 350 (36)	2 metal baskets with handles cut on both sides
3- compartment			
	PSO 3_3P	1070 x 1065 x 350 (56)	3 metal baskets with handles cut on both sides
	PSO 3_3W	1070 x 1065 x 350 (38)	3 frames onto which bags are hung
	PSO 3_2P_1W	1070 x 1065 x 350 (50)	- 2 metal baskets with handles cut on both sides - 1 frame onto which bags are hung
	PSO 3_2W_1P	1070 x 1065 x 350 (44)	- 1 metal basket with handles cut on both sides - 2 frames onto which bags are hung
4- compartment			
	PSO 4_4P	1070 x 1420 x 350	4 metal baskets with handles cut on both sides

	PSO 4_4W	1070 x 1420 x 350 (51)	4 frames onto which bags are hung
	PSO 4_3P_1W	1070 x 1420 x 350 (69)	- 3 metal baskets with handles cut on both sides - 1 frame onto which bags are hung
	PSO 4_3W_1P	1070 x 1420 x 350 (57)	- 1 metal basket with handles cut on both sides - 3 frames onto which bags are hung
	PSO 4_2P_2W	1070 x 1420 x 350 (63)	- 2 metal baskets with handles cut on both sides - 2 frames onto which bags are hung
Large bin			
	PSO D/1W	1070 x 710 x 350 (22)	- 1 metal frame onto which bags are hung (dimensions: 615 wide x 266 deep)

ADDITIONAL EQUIPMENT OPTIONS AVAILABLE IN THE RECYCLING BINS

Key locks with a single number, all compartments in the bin are open with a single key (1 pc)

4 casters, including 2 casters with brake (a set)



Bin made of galvanised sheet metal (1 pc) (applies to PSO 1, PSO 2, PSO 3, PSO 4)



Levelling feet (4 pcs.)

4 stands

Door stop

Extra metal information plate, screwed onto back casing wall (200 mm wide)

SPORT LOCKERS			
 <p>Lockers painted with all RAL colours. Our products are covered by 24-months warranty. Delivered lockers are completely assembled, still shelves need to be mounted.</p>			
	SKU	DIMENSIONS [mm] H x W x D (WEIGHT [kg])	ADDITIONAL DESCRIPTION
WITH FULL HINGED DOORS			
	SzT 2D800/04	2000 x 800 x 500 (73)	<ul style="list-style-type: none"> - hinged doors are provided with reinforced inner profiles, - doors are provided with internal hinges, giving free access to the furniture interior, - doors are locked with a key lock with a hand wheel, with 3-point locking system - locker provided with 4 shelves with edge, adjustable every 15 mm
	SzT 2D900/04	2000 x 900 x 500 (77)	
	SzT 2D1000/04	2000 x 1000 x 500 (83)	
	SzT 2D1200/04	2000 x 1200 x 500 (95)	
WITH FULL HINGED DOORS + A RAIL AND 4 HOOKS			
	SzT 2D800/3H	2000 x 800 x 500 (74)	<p>Hinged doors are provided with reinforcing inner profiles,</p> <ul style="list-style-type: none"> - doors are provided with internal hinges, giving free access to the furniture interior, - doors are locked with a key lock with a hand wheel, with 3-point locking system. <p>The locker is provided with:</p> <ul style="list-style-type: none"> - 3 shelves with edge, adjustable every 15 mm - 1 shelf with a rail and 4 coat hooks
	SzT 2D900/3H	2000 x 900 x 500 (78)	
	SzT 2D1000/3H	2000 x 1000 x 500 (84)	
	SzT 1200/3H	2000 x 1200 x 500 (96)	
WITH FULL HINGED DOORS + COMPLETE EQUIPMENT			
	SzT 2D800/W4	2000 x 800 x 500 (68)	<ul style="list-style-type: none"> - hinged doors are provided with reinforcing inner profile, - doors are provided with internal hinges, giving free access to the furniture interior, - doors are locked with a key lock with a hand wheel, with 3-point locking system.

	SzT 2D900/W4	2000 x 900 x 500 (74)	<p>The locker is provided with:</p> <ul style="list-style-type: none"> - safe compartment locked with a key lock and 2 hula-hoop rails - sections for poles, <ul style="list-style-type: none"> - tub, - baseball bats holders, <ul style="list-style-type: none"> - ball basket, - 3 hooks
	SzT 2D1000/W4	2000 x 1000 x 500 (78)	
	SzT 2D1200/W4	2000 x 1200 x 500 (90)	
WITH PERFORATED HINGED DOORS			
	SzT 2O800/04	2000 x 800 x 500 (71)	<ul style="list-style-type: none"> - hinged doors are provided with reinforced inner profile, - doors are provided with internal hinges, giving free access to the furniture interior, - doors are locked with a key lock with a hand wheel, with 3-point locking system - doors provided with square-shaped perforations, - locker provided with 4 shelves with edge, adjustable every 15 mm
	SzT 2O900/04	2000 x 900 x 500 (75)	
	SzT 2O1000/04	2000 x 1000 x 500 (81)	
	SzT 2O1200/04	2000 x 1200 x 500 (93)	
PERFORATED HINGED DOORS + A RAIL AND 4 COAT HOOKS			
	SzT 2O800/3H	2000 x 800 x 500 (72)	<ul style="list-style-type: none"> - hinged doors are provided with reinforced inner profile, - doors are provided with internal hinges, giving free access to the furniture interior, - doors are locked with a key lock with a hand wheel, with 3-point locking system - doors provided with square-shaped perforations. <p>The locker is provided with:</p> <ul style="list-style-type: none"> - 3 shelves with edge, adjustable every 15 mm - 1 shelf with a rail and 4 coat hooks
	SzT 2O900/3H	2000 x 900 x 500 (76)	
	SzT 2O1000/3H	2000 x 1000 x 500 (82)	

	SzT 201200/3H	2000 x 1200 x 500 (94)	
--	------------------	---------------------------	--

PERFORATED HINGED DOORS + COMPLETE EQUIPMENT			
	SzT 20800/W4	2000 x 800 x 500 (66)	<ul style="list-style-type: none"> - hinged doors are provided with 2 reinforcing inner profiles, - doors are provided with internal hinges, giving free access to the furniture interior, - doors are locked with a key lock with a hand wheel, with 3-point locking system - doors provided with square-shaped perforations. <p>The locker is provided with:</p> <ul style="list-style-type: none"> - safe compartment locked with a key lock and 2 hula-hoop rails - sections for poles, - tub, - baseball bats holders, - ball basket, - 3 hooks
	SzT 20900/W4	2000 x 900 x 500 (72)	
	SzT 201000/W4	2000 x 1000 x 500 (76)	
	SzT 201200/W4	2000 x 1200 x 500 (88)	
FULL SLIDING DOORS			

	<p>ST DS1500/W1+1</p>	<p>2000 x 1500 x 500 (101)</p>	<ul style="list-style-type: none"> - sliding doors are provided with a flash handle and are locked with a key lock <p>The locker is provided with:</p> <ul style="list-style-type: none"> - 4 shelves with edges on all sides, adjustable every 15 mm = 8 shelves
---	---------------------------	------------------------------------	---

SLIDING DOORS + COMPLETE EQUIPMENT







	<p>SzT DS1500/W4+1</p>	<p>2000 x 1500 x 500 (98)</p>	<ul style="list-style-type: none"> - doors are provided with a flash handle and are locked with a key lock, with 3-point locking system. <p>Left part of the locker is provided with:</p> <ul style="list-style-type: none"> - safe compartment locked with a key lock and 2 hula-hoop rails <ul style="list-style-type: none"> - sections for poles, <ul style="list-style-type: none"> - tub, - baseball bats holders, - ball basket, - 3 hooks <p>Right part of the locker is provided with:</p> <ul style="list-style-type: none"> - 4 shelves with edge, adjustable every 15 mm
--	----------------------------	-----------------------------------	--



PERFORATED SLIDING DOORS

	<p>SzT DP1500/W1+1</p>	<p>2000 x 1500 x 500 (99)</p>	<ul style="list-style-type: none"> - sliding doors are provided with a flash handle and are locked with a key lock, - doors provided with square-shaped perforations. <p>The locker is provided with:</p> <ul style="list-style-type: none"> - 4 shelves with edges on all sides, adjustable every 15 mm (altogether 8 shelves) 	
---	----------------------------	-----------------------------------	--	--

PERFORATED SLIDING DOORS + COMPLETE EQUIPMENT

	<p>SzT DP1500/W4+1</p>	<p>2000 x 1500 x 500 (97)</p>	<p>- sliding doors are provided with a flash handle and are locked with a key lock, - doors provided with square-shaped perforations,</p> <p>Left part of the locker is provided with:</p> <ul style="list-style-type: none">- safe compartment locked with a key lock and 2 hula-hoop rails<ul style="list-style-type: none">- sections for poles,<ul style="list-style-type: none">- tub,- baseball bats holders,<ul style="list-style-type: none">- ball basket,- 3 hooks<p>Right part of the locker is provided with:</p><ul style="list-style-type: none">- 4 shelves with edge, adjustable every 15 mm	
---	----------------------------	-----------------------------------	--	--

LIGHT WORKBENCHES				
	<p>Light workbenches have very solid structure. The frame is made of sheet metal 1.5 mm thick.</p> <p>Drawers are mounted on the telescopic ball slides (with a stop, which prevents the drawer from falling out of the cabinet) providing smooth and easy extension. Maximum load bearing capacity of each drawer: 75 kg.</p> <p>A locker with hinged doors locked with a key lock.</p> <p>Table tops made of plywood 30 [mm] thick. Drawers are not locked with a key lock. Workbenches are provided with levelling feet.</p> <p><i>Frame in the workbenches can be painted with any RAL colour. Delivered workbenches are completely assembled.</i></p>			
	SKU	DIMENSION S [mm] H x W x D	ADDITIONAL DESCRIPTION (WEIGHT [kg])	
	600 wide			
		STL 600/5	850 X 600 X 600	<p>Workbench provided with back wall and 1 bottom shelf.</p> <p>It can be provided with 1 drawer suspended under the table top. (19)</p>
	STL 600/6	<p>Workbench is provided with 1 locker with hinged doors locked with a key lock. There is one permanently fixed shelf inside the locker; the table top and the locker is spaced apart by 120 [mm].</p> <p>The workbench can be optionally provided with:</p> <ul style="list-style-type: none"> - 1 drawer suspended under the table top - 3 drawers inside the locker with hinged doors <p>(32)</p>		
	STL 600/7	<p>Workbench is provided with 1 locker having 3 drawers of the following dimensions [mm]: external 154 H x 430 W x 542 D, internal 143 H x 390 W x 518 D, each.</p> <ul style="list-style-type: none"> - the table top and the locker are spaced apart by 120 [mm] <p>It can be provided with 1 drawer suspended under the table top (50)</p>		
1200 wide				
	STL 1200/1	850 X 1200 X 600	<p>Workbench provided with 1 back wall and 1 bottom shelf.</p> <p>It can be provided with 1 or 2 drawers suspended under the table top. (34)</p>	
	STL 1200/2		<p>1 suspended locker with 3 drawers of the following dimensions [mm]: external 154 H x 430 W x 542 D, internal 143 H x 390 W x 518 D, each.</p> <ul style="list-style-type: none"> - 1 locker with hinged doors. There is 1 permanently fixed shelf inside the locker. 	

		<ul style="list-style-type: none"> - the table top and the locker is spaced apart by 120 [mm], The workbench can be optionally provided with: <ul style="list-style-type: none"> - 1 or 2 drawers suspended under the table top, - 3 internal drawers (inside the locker with hinged doors) (74)
	STL 1200/3	<p>The workbench is provided with 2 suspended lockers, each of them having 3 drawers.</p> <ul style="list-style-type: none"> - each locker has 3 drawers with the following dimensions [mm]: external 154 H x 430 W x 542 D, internal 143 H x 390 W x 518 D, each. - the table top and the locker are spaced apart by 120 [mm] <p>It can be provided with 1 or 2 drawers suspended under the table top. (98)</p>
	STL 1200/4	<p>Workbench is provided with 2 lockers with hinged doors. Each locker has 1 permanently fixed shelf.</p> <ul style="list-style-type: none"> - the table top and the locker are spaced apart by 120 [mm] <p>The workbench can be optionally provided with:</p> <ul style="list-style-type: none"> - 1 or 2 drawers suspended under the table top, - 3 drawers inside the lockers with hinged doors (59)

TYPES OF DRAWERS IN LIGHT WORKBENCHES		
	width 600	width 1200
1 drawer suspended under the table top of the following dimensions [mm]: external 90 X 435 X 421, internal 75 x 351 x 378		
1 internal drawer of the following dimensions [mm]: external 154 X 384 X 517, internal 142 x 350 x 495 each, in hinged door locker		

TYPES OF TOPS IN LIGHT WORKBENCHES		
	width 600	width 1200
Top coated with waterproof varnish with increased abrasion resistance.		
Top made of plywood coated with corrugated rubber		
Top made of plywood covered with inox sheet metal		
Top made of plywood covered with galvanised sheet metal		

HEAVY-DUTY WORKBENCHES



Reinforced frame is made of full profiles 40 x 20, which are 1.50 [mm] thick, and 40 x 40 which are 2.0 [mm] thick,

- lockers with hinged doors locked with a key lock,

- Drawers are mounted on the telescopic ball slides (with a stop, which prevents the drawer from falling out of the cabinet) providing smooth and easy extension.

Drawers are provided with a patented mechanism, with which only one drawer can be open at a time, which consequently prevents the cabinet from falling down.

Drawers are locked with a master key-lock.

- each drawer is provided with a sticker to mark its content.

- table top is made of plywood 40 [mm] thick +/- 4 [mm],



- workbench is provided with levelling feet.





Thanks to massive structure, workbenches can be provided with a number of optional elements, with no risk for their stability.



To make the furniture even more functional it is additionally provided with power sockets, lockers with drawers or shelves, or containers.



Frame in the workbenches can be painted with any RAL colour.



Delivered workbenches are completely assembled.



	SKU	DIMENSION S [mm] H x W x D	ADDITIONAL DESCRIPTION (WEIGHT [kg])
1100 wide			
	STC 1100/2321	884 x 1100 x 750	The workbench is provided with: 1 locker with hinged doors (useful dimensions [mm] 633 high x 386 wide x 609 deep, external dimension of the locker 748 high x 462 wide x 670 deep). Locker with a permanently fixed shelf mounted on the half of its height. 2 drawers "90W" (drawers dimensions [mm]: external 85 high x 412 wide x 610 deep, internal 80 high x 368 wide x 558 deep). 1 locker with hinged doors. Locker useful dimensions [mm]: 422 high x 386 wide x 609 deep. Locker with no shelf (75)
1500 wide			
	STC 1500/000000	850 x 1500 x 700	The workbench is provided with: 1 suspended box "120" (external dimensions 115 x 567 x 595, internal dimensions 110 x 522 x 560). The box is assembled on telescopic ball-bearing slides with protection against falling out. The box is locked with a central lock.
	STC 1500/0102		

	<p>STC 1500/0602</p>		<p>The workbench is provided with:</p> <ul style="list-style-type: none"> 2 drawers "90" (drawer dimensions [mm]: external 85 X 567 X 595, internal 80 x 522 x 558), 1 drawer "120" (drawer dimensions [mm]: external 115 X 567 X 595, internal 110 x 522 x 558), 1 drawer "180" (drawer dimensions [mm]: external 175 X 567 X 595, internal 170 x 522 x 558). 1 suspended locker with hinged doors. Locker is provided with 1 permanently fixed shelf (102)
	<p>STC 1500/0606</p>		<p>Workbench is provided with 2 suspended containers, each of which is equipped with:</p> <ul style="list-style-type: none"> 2 drawers "90" (drawer dimensions [mm]: external 85 X 567 X 595, internal 80 x 522 x 558), 1 drawer "120" (drawer dimensions [mm]: external 115 X 567 X 595 and the following internal dimensions 110 x 522 x 558), 1 drawer "180" (drawer dimensions [mm]: external 175 X 567 X 595, internal 170 x 522 x 558) (122)
	<p>STC 1500/0215</p>		<p>The workbench is provided with:</p> <ul style="list-style-type: none"> 2 drawers "90" (drawer dimensions [mm]: external 85 X 567 X 595, internal 80 x 522 x 558), 1 drawer "120" (drawer dimensions [mm]: external 115 X 567 X 595, internal 110 x 522 x 558), 1 drawer "180" (drawer dimensions [mm]: external 175 X 567 X 595, internal 170 x 522 x 558) (85)
	<p>STC 1500/202S2S</p>	<p>884 x 1500 x 750</p>	<p>The workbench is provided with:</p> <ul style="list-style-type: none"> 3 drawers "210W" with the following dimensions [mm]: external 205 H x 415 W x 610 D, internal 200 H x 368 W x 558 D, each. (75)
	<p>STC 1500/21221S</p>	<p>884 x 1500 x 750</p>	<p>The workbench is provided with:</p> <ul style="list-style-type: none"> 2 drawers "90W" (drawers dimensions [mm]: external 85 H x 412 W x 610 D, internal 80 H x 368 W x 558 D). Drawers are mounted on the telescopic ball slides (with a stop, which prevents the drawer from falling out of the cabinet) providing smooth and easy extension.

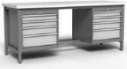
			<p>Drawers are provided with a patented mechanism, with which only one drawer can be open at a time, which consequently prevents the cabinet from falling down.</p> <p>Drawers are locked with a master key-lock.</p> <p>1 locker with hinged doors locked with a key lock. Locker useful dimensions [mm]: 422 H x 386 W x 609 D. Locker with no shelf.</p> <p>1 drawer "180W" with the following dimensions [mm]: external 175 H x 412 W x 610 D, internal 170 H x 368 W x 558 D. Drawer is mounted on the telescopic ball slides (with a stop, which prevents the drawer from falling out of the cabinet) providing smooth and easy extension. Drawer is locked with a master key-lock.</p> <p>1 locker with hinged doors locked with a key lock. Locker useful dimensions [mm]: 422 H x 386 W x 609 D. Locker with no shelf.</p> <p>1 locker made of varnished plywood - [mm] 428 W x 670 D x 30 H (90)</p>
2000 wide			
	STC 2000/000000		(50)
	STC 2000/210000 /111	850 X 2000 X 700	<p>Workbench is provided with:</p> <ul style="list-style-type: none"> 1 suspended locker with: <ul style="list-style-type: none"> - 1 "120" drawer (usable dimensions [mm]: H 115 x W 522 x D 558), - 2 "90" drawers (usable dimensions [mm]: H 85 x W 522 x D 558), - 3 "60" drawers (usable dimensions [mm]: H 55 x W 522 x D 558), Perforated wall made of 3 panels, each of which is [mm] 896 x 629. Panels are fastened to the workbench by means of mounting rails, 1 lighting panel on the frame fixed to the perforated wall; the said panel comprises: a switch, 230 V supply socket and two G13 fluorescent lamp of 58W.
	STC 2000/O- PZ-062		<p>Workbench is provided with:</p> <ul style="list-style-type: none"> 1 suspended locker with: <ul style="list-style-type: none"> - 1 "180" drawer (drawer's usable dimensions [mm]: H 175 x W 522 x D 558), - 1 "120" drawer (drawer's usable dimensions [mm]: H 115 x W 522 x D 558), - 2 "90" drawers (drawer's usable dimensions [mm]: H 85 x W 522 x D 558), 1 locker with hinged door and internal shelf - external dimensions of the locker [mm]: 598 H x 618W x 670 D 1 suspended locker with:

			<ul style="list-style-type: none"> - 1 "180" drawer (drawer's usable dimensions [mm]: H 175 x W 522 x D 558), - 1 "120" drawer (drawer's usable dimensions [mm]: H 115 x W 522 x D 558), - 2 "90" drawers (drawer's usable dimensions [mm]: H 85 x W 522 x D 558), <ul style="list-style-type: none"> • Perforated wall made of 3 panels, each of which is [mm] 896 x 629. Panels are fastened to the workbench by means of mounting rails, • 1 lighting panel on the frame fixed to the perforated wall; the said panel comprises: a switch, 230 V supply socket and two G13 fluorescent lamp of 58W. • mounting rails for containers with the following containers: - 21 polypropylene PW 5 containers having the following dimensions (D x W x H) 119x77x 56 [mm], - 15 polypropylene PW 4 containers having the following dimensions (D x W x H) 157x101x74 [mm].
	<p>STC 2000/050006</p>		<p>Workbench is provided with:</p> <p>1 suspended container with:</p> <ul style="list-style-type: none"> - 2 drawers "90" (drawer dimensions [mm]: external 85 X 567 X 595, internal 80 x 522 x 558) - 1 drawer "120" (drawer dimensions [mm]: external 115 X 567 X 595, internal 110 x 522 x 558) - 1 drawer "180" (drawer dimensions [mm]: external 175 X 567 X 595, internal 170 x 522 x 558). <p>1 suspended container with:</p> <ul style="list-style-type: none"> - 2 drawers "60" (drawer dimensions [mm]: external 55 X 567 X 610, internal 50 x 522 x 558) - a locker with hinged doors (140)
	<p>STC 2000/060006 /213</p>		<p>Workbench is provided with:</p> <p>2 suspended containers with:</p> <ul style="list-style-type: none"> - 2 drawers "90" (drawer dimensions [mm]: external 85 X 567 X 595, internal 80 x 522 x 558) - 1 drawer "120" (drawer dimensions [mm]: external 115 X 567 X 595, internal 110 x 522 x 558) - 1 drawer "180" (drawer dimensions [mm]: external 175 X 567 X 595, internal 170 x 522 x 558). <p>Perforated wall made of 3 panels, each of which is [mm] 896 x 629. Panels are fastened to the workbench by means of mounting rails,</p> <p>1 shelf with the following dimensions [mm] 631 x 372 The shelf structure is suitable to mount it on a chosen height directly on the mounting rails,</p>

		<p>1 suspended locker of the following dimensions [mm] 480 x 632 x 272 , with hinged doors. The locker is locked with a key lock, while inner side of the doors is perforated to mount hooks for tools. Thanks to mounting rails located inside the locker, the shelf can be mounted on a chosen height,</p> <p>1 lighting panel on the frame mounted on the workbench; the said panel comprises: a switch, 230 V supply socket and two G13 fluorescent lamp of 58W. (173)</p>
	<p>STC 2000/020006</p>	<p>Workbench is provided with:</p> <p>1 suspended container with:</p> <ul style="list-style-type: none"> - 2 drawers "90" (drawer dimensions [mm]: external 85 X 567 X 595, internal 80 x 522 x 558) - 1 drawer "120" (drawer dimensions [mm]: external 115 X 567 X 595, internal 110 x 522 x 558) - 1 drawer "180" (drawer dimensions [mm]: external 175 X 567 X 595, internal 170 x 522 x 558). <p>1 suspended locker with hinged doors. Locker is provided with 1 permanently fixed shelf (100)</p>
	<p>STC 2000/060006</p>	<p>Workbench is provided with:</p> <p>2 suspended containers with:</p> <ul style="list-style-type: none"> - 2 drawers "90" (drawer dimensions [mm]: external 85 X 567 X 595, internal 80 x 522 x 558) - 1 drawer "120" (drawer dimensions [mm]: external 115 X 567 X 595, internal 110 x 522 x 558) - 1 drawer "180" (drawer dimensions [mm]: external 175 X 567 X 595, internal 170 x 522 x 558) <p>(130)</p>
	<p>STC 2000/020602</p>	<p>Workbench is provided with:</p> <p>1 suspended container with:</p> <ul style="list-style-type: none"> - 2 drawers "90" (drawer dimensions [mm]: external 85 X 567 X 595, internal 80 x 522 x 558) - 1 drawer "120" (drawer dimensions [mm]: external 115 X 567 X 595, internal 110 x 522 x 558) - 1 drawer "180" (drawer dimensions [mm]: external 175 X 567 X 595, internal 170 x 522 x 558). <p>2 suspended lockers with hinged doors. Each locker has 1 permanently fixed shelf (150)</p>
	<p>STC 2000/000006</p>	<p>Workbench is provided with 1 suspended container with:</p> <ul style="list-style-type: none"> 2 drawers "90" (drawer dimensions [mm]: external 85 X 567 X 595, internal 80 x 522 x 558), 1 drawer "120" (drawer dimensions [mm]: external 115 X 567 X 595, internal 110 x 522 x 558),

			1 drawer "180" (drawer dimensions [mm]: external 175 X 567 X 595, internal 170 x 522 x 558). (90)
	STC 2000/121102		4 drawers "120" (drawer dimensions [mm]: external 115 X 567 X 595, internal 110 x 522 x 558), 3 drawers "160" (drawer dimensions [mm]: external 155 X 567 X 595, internal 150 x 522 x 558). 1 suspended locker with hinged doors. Locker is provided with 1 permanently fixed shelf (150)
	STC 2000/010001	890 x 2000 x 700 (95)	2 suspended drawers with the following internal dimensions [mm] 110 x 522 x 587 each. Each drawer: - is mounted on the telescopic ball slides (with a stop, which prevents the drawer from falling out of the cabinet) providing smooth and easy extension. - is locked with a master key-lock.

TYPES OF TOPS IN HEAVY-DUTY WORKBENCHES		
	width 1500	width 2000
Top coated with waterproof varnish with increased abrasion resistance.		
Top made of plywood coated with corrugated rubber		
Top made of plywood covered with inox sheet metal		
Top made of plywood covered with galvanised sheet metal		

ADDITIONAL EQUIPMENT OPTIONS AVAILABLE IN THE HEAVY-DUTY WORKBENCHES		
	width 1500	width 2000
Perforated wall 500 mm high: 2 panels in the workbenches 1500 wide or 3 panels in the workbenches 2000 wide		
Perforated wall 900 mm high: 2 panels in the workbenches 1500 wide or 3 panels in the workbenches 2000 wide		
1 shelf (the shelf is exclusively sold with the wall)		
1 suspended locker, with perforations on the doors and adjustable shelf (the locker is exclusively sold with the perforated wall)		
1 lighting panel with a frame (exclusively sold with the perforated wall)		
4 casters, including 2 casters with brake - for all types of workbenches		

 TYPES OF PARTITIONS FOR DRAWERS IN HEAVY-DUTY WORKBENCHES		
	width 1500	width 2000
PS1/90- for drawers „90” 3 partitions, each provided with 3 sections. Distance between partitions 145 mm, distance between sections 25 mm		
PS2/90- for drawers „90” 4 partitions, each provided with 3 sections. Distance between partitions 109 mm, distance between sections 25 mm		
PS1/120- for drawers „120” 3 partitions, each provided with 3 sections. Distance between partitions 145 mm, distance between sections 25 mm		
PS2/120- for drawers „120” 4 partitions, each provided with 3 sections. Distance between partitions 109 mm, distance between sections 25 mm		

CUSTOMISED WORKBENCHES

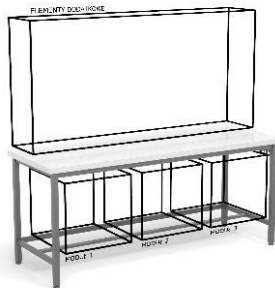

Reinforced frame is made of full steel profiles 40 x 20, which are 1.50 [mm] thick, and 40 x 40 which are 2.0 [mm] thick,
- lockers with hinged doors locked with a key lock,

Thanks to massive structure, workbenches can be provided with a number of optional elements, with no risk for their stability.

STC K 1500 can be provided with:



- 2 modules,
- additional elements





STC K 2000 can be provided with:







- 3 modules,
- additional elements.







To improve functionality workbenches are also provided with power sockets.







Frame in the workbenches can be painted with any RAL colour. Delivered workbenches are completely assembled.



	SKU	DIMENSION S [mm] H x W x D	ADDITIONAL DESCRIPTION (WEIGHT [kg])
1500 wide			
	STC K 1500	850 x 1500 x 700	
	STC K 2000	850 x 2000 x 700	





EQUIPMENT FOR MODULE 1, 2 OR 3 IN STC K 1500 AND STC K 2000 WORKBENCHES		
SWM1		A locker with hinged door and internal shelf - external dimensions of the locker [mm]: 598 H x 618 W x 670 D; usable dimensions [mm]: 486 H
SWM2		A locker with hinged door + 2 drawers x 60 - external dimensions of the locker [mm]: 598 H x 618 W x 670 D; usable dimensions of the locker with hinged door [mm]: 330 H; usable dimensions of drawers [mm]: 55 H x 522 W x 558 D, each.
SWM3		A locker with hinged door + 1 drawer x 120 - external dimensions of the locker [mm]: 598 H x 618 W x 670 D; usable dimensions of the locker with hinged door [mm]: 330 H; usable dimensions of the drawer [mm]: 115 H x 522 W x 558 D
SWM5		A locker with 2 drawers x 240 - external dimensions of the locker [mm]: 598 H x 618 W x 670 D; usable dimensions of the drawers [mm]: 235 H 522 W x 558 D, each
SWM6		A locker with 1 drawer x 120 and 2 drawers x 180 - external dimensions of the locker [mm]: 598 H x 618 W x 670 D; usable dimensions of the drawers [mm]: 1 x 115 H x 522 W x 558 D, 2 x 175 H x 522 W x 558 D



SWM7		<p>A locker with 2 drawers x 120 and 1 drawer x 240 - external dimensions of the locker [mm]: 598 H x 618 W x 670 D; usable dimensions of the drawers [mm]: 1 x 115 H x 522 W x 558 D, 1 x 235 H x 522 W x 558 D</p>
SWM8		<p>A locker with 3 drawers x 160 - external dimensions of the locker [mm]: 598 H x 618 W x 670 D; usable dimensions of the drawers [mm]: 3 x 155 H x 522 W x 558 D</p>
SWM9		<p>A locker with 1 drawer x 150, 2 drawers x 120, 1 drawer x 90 - external dimensions of the locker [mm]: 598 H x 618 W x 670 D; usable dimensions of the drawers [mm]: 1 x 145 H x 522 W x 558 D, 2 x 115 H x 522 W x 558 D and 1 x 85 H x 522 W x 558 D</p>
SWM10		<p>A locker with 1 drawer x 180, 1 drawer x 120, 2 drawers x 90 - external dimensions of the locker [mm]: 598 H x 618 W x 670 D; usable dimensions of the drawers [mm]: 1 x 175 H x 522 W x 558 D, 1 x 115 H x 522 W x 558 D and 2 x 85 H x 522 W x 558 D</p>
SWM11		<p>A locker with 2 drawers x 150, 1 drawer x 120, 1 drawer x 60 - external dimensions of the locker [mm]: 598 H x 618 W x 670 D; usable dimensions of the drawers [mm]: 1 x 145 H x 522 W x 558 D, 1 x 115 H x 522 W x 558 D and 1 x 55 H x 522 W x 558 D</p>
SWM12		<p>A locker with 2 drawers x 150 and 2 drawers x 90 - external dimensions of the locker [mm]: 598 H x 618 W x 670 D; usable dimensions of the drawers [mm]: 2 x 145 H x 522 W x 558 D, 2 x 85 H x 522 W x 558 D</p>

SWM13		<p>A locker with 4 drawers x 120 - external dimensions of the locker [mm]: 598 H x 618 W x 670 D; usable dimensions of the drawers [mm]: 4 x 115 H x 522 W x 558 D</p>
SWM14		<p>A locker with 1 drawer x 120 and 4 drawers x 90 - external dimensions of the locker [mm]: 598 H x 618 W x 670 D; usable dimensions of the drawers [mm]: 1 x 115 H x 522 W x 558 D, 4 x 85 H x 522 W x 558 D</p>
SWM15		<p>A locker with 1 drawer x 150, 1 drawer x 120, 1 drawer x 90 and 2 drawers x 60 - external dimensions of the locker [mm]: 598 H x 618 W x 670 D; usable dimensions of the drawers [mm]: 1 x 145 H x 522 W x 558 D, 1 x 115 H x 522 W x 558 D, 1 x 85 H x 522 W x 558 D and 2 x 55 H x 522 W x 558 D</p>
SWM16		<p>A locker with 1 drawer x 150, 3 drawers x 90, 1 drawer x 60 - external dimensions of the locker [mm]: 598 H x 618 W x 670 D; usable dimensions of the drawers [mm]: 1 x 145 H x 522 W x 558 D, 3 x 85 H x 522 W x 558 D and 1 x 55 H x 522 W x 558 D</p>
SWM17		<p>A locker with 2 drawers x 120, 2 drawers x 90, 1 drawer x 60 - external dimensions of the locker [mm]: 598 H x 618 W x 670 D; usable dimensions of the drawers [mm]: 2 x 115 H x 522 W x 558 D, 2 x 85 H x 522 W x 558 D and 1 x 55 H x 522 W x 558 D</p>
SWM18		<p>A locker with 2 drawers x 150 and 3 drawers x 60 - external dimensions of the locker [mm]: 598 H x 618 W x 670 D; usable dimensions of the drawers [mm]: 2 x 145 H x 522 W x 558 D, and 3 x 55 H x 522 W x 558 D</p>

SWM19		<p>A locker with 3 drawers x 120 and 2 drawers x 60 - external dimensions of the locker [mm]: 598 H x 618 W x 670 D; usable dimensions of the drawers [mm]: 3 x 115 H x 522 W x 558 D, and 2 x 55 H x 522 W x 558 D</p>
SWM20		<p>A locker with 1 drawer x 120, 2 drawers x 90, 3 drawers x 60 - external dimensions of the locker [mm]: 598 H x 618 W x 670 D; usable dimensions of the drawers [mm]: 1 x 115 H x 522 W x 558 D, 2 x 85 H x 522 W x 558 D and 3 x 55 H x 522 W x 558 D</p>
SWM21		<p>A locker with 2 drawers x 120 and 4 drawers x 60 - external dimensions of the locker [mm]: 598 H x 618 W x 670 D; usable dimensions of the drawers [mm]: 2 x 115 H x 522 W x 558 D, and 4 x 55 H x 522 W x 558 D</p>
SWM22		<p>A locker with 4 drawers x 90 and 2 drawers x 60 - external dimensions of the locker [mm]: 598 H x 618 W x 670 D; usable dimensions of the drawers [mm]: 4 x 85 H x 522 W x 558 D, and 2 x 55 H x 522 W x 558 D</p>
SWM23		<p>A locker with 1 drawer x 120 and 6 drawers x 60 - external dimensions of the locker [mm]: 598 H x 618 W x 670 D; usable dimensions of the drawers [mm]: 1 x 115 H x 522 W x 558 D, and 6 x 55 H x 522 W x 558 D</p>
SWM24		<p>A locker with 2 drawers x 90 and 5 drawers x 60 - external dimensions of the locker [mm]: 598 H x 618 W x 670 D; usable dimensions of the drawers [mm]: 2 x 85 H x 522 W x 558 D, and 5 x 55 H x 522 W x 558 D</p>

SWM25		A locker with 8 drawers x 60 - external dimensions of the locker [mm]: 598 H x 618 W x 670 D; usable dimensions of the drawers [mm]: 8 x 55 H x 522 W x 558 D
SWM26		Suspended box with 1 drawer x 120 - external dimensions of the box [mm]: 191 H x 618 W x 670 D; usable dimensions of the drawer [mm]: 1 x 115 H x 522 W x 558 D
SWM34		Suspended box with 2 drawers x 60 - external dimensions of the box [mm]: 191 H x 618 W x 670 D; usable dimensions of the drawers [mm]: 2 x 55 H x 522 W x 522 D

ADDITIONAL ELEMENTS FOR STC K 1500 AND STC K 2000 WORKBENCHES		
29.		A lighting panel for 1500 workbench with 2 x 36 W - external dimensions [mm]: 420 H x 1287 W x 500 D - alternatively LED 2 x 14,5 W
30.		A lighting panel for 2000 workbench with 2 x 58W - external dimensions [mm]: 420 H x 1907 W x 500 D - alternatively LED 2 x 20 W
31.		Perforated wall (2 panels x 500 mm H) - external dimensions of the wall [mm]: 1220 H x 1302 W x 45 D; usable dimensions of the panels [mm]: 2 x 496 H x 629 W
32.		Perforated wall (3 panels x 500 mm H) - external dimensions of the wall [mm]: 1220 H x 1934 W x 45 D; usable dimensions of the panels [mm]: 3 x 496 H x 629 W
33.		Perforated wall (2 panels x 900 mm H) - external dimensions of the wall [mm]: 1620 H x 1302 W x 45 D; usable dimensions of the panels [mm]: 2 x 896 H x 629 W

34.		Perforated wall (3 panels x 900 mm H) - external dimensions of the wall [mm]: 1620 H x 1934 W x 45 D; usable dimensions of the panels [mm]: 3 x 896 H x 629 W
35.		A locker mounted on the perforated wall, with internal shelf - external dimensions of the locker [mm]: 480 H x 632 W x 272 D; usable dimensions [mm]: 250 D
36.		A shelf mounted on the perforated wall - external dimensions of the shelf [mm]: 630 W x 372 D; usable dimensions [mm]: 350 D

FREE-STANDING WORKSHOP CUPBOARDS



Workshop cupboards with drawers have solid reinforced structure. Cupboards can be provided with drawers of different size. The drawers interiors are subject to custom-made arrangements with metal partitions, making it easy to store tools and small objects, or optionally can be provided with foam inserts.

Drawers are mounted on the telescopic ball slides (with a stop, which prevents the drawer from falling out of the cabinet) providing smooth and easy extension.





Cupboards are provided with a patented mechanism, with which only one drawer can be open at a time, which consequently prevents the cupboard from falling down.









Drawers and cupboards are locked with a master key-lock.

Cupboards are provided with levelling feet.

Cupboards are painted with all RAL colours.

Delivered cupboards are completely assembled.



	SKU	DIMENSIONS [mm] H x W x D (WEIGHT [kg])	ADDITIONAL DESCRIPTION
	SSW 901	1072 x 1005 x 590 (103)	<ul style="list-style-type: none"> - 1 drawer "80" (drawer dimensions [mm]: external 75 X 950 X 523, internal 62 X 905 X 473, Weight: 7kg - 2 drawers "120" (drawer dimensions [mm]: external 115 X 950 X 523, internal 102 X 905 X 473, Weight: 8kg - 2 drawers "160" (drawer dimensions [mm]: external 155 X 950 X 523, internal 142 X 905 X 473, Weight: 9kg - 1 drawer "280" (drawer dimensions [mm]: external 275 X 950 X 523, internal 262 x 905 x 473 Weight: 12kg
	SSW 902	1072 x 1005 x 590 (102)	<ul style="list-style-type: none"> - 5 drawers "80" (drawer dimensions [mm]: external 75 X 950 X 523, internal 62 X 905 X 473, Weight: 7kg - 2 drawers "120" (drawer dimensions [mm]: external 115 X 950 X 523, internal 102 X 905 X 473, Weight: 8kg - 1 drawer "280" (drawer dimensions [mm]: external 275 X 950 X 523, internal 262 x 905 x 473
	SSW 903	1072 x 1005 x 590 (91)	<ul style="list-style-type: none"> - 1 drawer "160" (drawer dimensions [mm]: external 155 X 950 X 523, internal 142 X 905 X 473, Weight: 9kg - 2 drawers "240" (drawer dimensions [mm]: external 235 X 950 X 523, internal 222 X 905 X 473, Weight: 11kg - 1 drawer "280" (drawer dimensions [mm]: external 275 X 950 X 523, internal 262 x 905 x 473 Weight: 12kg
	SSW 904	1072 x 1005 x 590 (102)	<ul style="list-style-type: none"> - 3 drawers "80" (drawer dimensions [mm]: external 75 X 950 X 523, internal 62 X 905 X 473, Weight: 7kg - 1 drawer "160" (drawer dimensions [mm]: external 155 X 950 X 523, internal 142 X 905 X 473, Weight: 9kg - 1 drawer "240" (drawer dimensions [mm]: external 235 X 950 X 523, internal 222 X 905 X 473, Weight: 11kg - 1 drawer "280" (drawer dimensions [mm]: external 275 X 950 X 523, internal 262 x 905 x 473 Weight: 12kg

	SSW 905	1072 x 1005 x 590 (123)	- 7 drawers "80" (drawer dimensions [mm]: external 75 X 950 X 523, internal 62 X 905 X 473, Weight: 7kg - 3 drawers "120" (drawer dimensions [mm]: external 115 X 950 X 523, internal 102 x 905 x 473 Weight: 8kg
	SSW 906	1072 x 1005 x 590 (128)	- 10 drawers "80" (drawer dimensions [mm]: external 75 X 950 X 523, internal 62 X 905 X 473, Weight: 7kg - 1 drawer "120" (drawer dimensions [mm]: external 115 X 950 X 523, internal 102 x 905 x 473 Weight: 8kg
	SSW 907	1072 x 650 x 655 (91)	- 1 drawer "80" (drawer dimensions [mm]: external 75 X 595 X 592, internal 62 X 549 X 539, Weight: 7kg - 2 drawers "120" (drawer dimensions [mm]: external 115 X 595 X 592, internal 102 X 549 X 539, Weight: 8kg - 2 drawers "160" (drawer dimensions [mm]: external 155 X 595 X 592, internal 142 X 549 X 539, Weight: 9kg - 1 drawer "280" (drawer dimensions [mm]: external 275 X 595 X 592, internal 262 x 549 x 539 Weight: 12kg
	SSW 908	1072 x 650 x 655 (50)	- 1 drawer "80" (drawer dimensions [mm]: external 75 X 595 X 592, internal 62 X 549 X 539, Weight: 7kg - 1 drawer "200" (drawer dimensions [mm]: external 195 X 595 X 592, internal 182 x 549 x 539, - 1 locker with hinged doors locked with a key lock. There is 1 permanently fixed shelf inside the locker.
	SSW 909	1072x1005x590 (90)	- 1 drawer "200" (drawer dimensions [mm]: external 195 X 950 X 523, internal 182 X 905 X 473, Weight: 10.2kg - 3 drawers "240" (drawer dimensions [mm]: external 235 X 950 X 523, internal 222 x 905 x 473 Weight: 11kg
	SSW 910	635 x 800 x 590 (70)	- 2 drawers "115" (drawer dimensions [mm]: internal 106 H x 323 W x 378 D - 1 drawer "235" (drawer dimensions [mm]: internal 226 H x 323 W x 378 D External depth of drawers is 523 mm
	SSW 911	800 x 520 x 665 (58)	- 1 drawer "80" (drawer dimensions [mm]: internal 52 H x 424 W x 550 D - 1 drawer "80" (drawer dimensions [mm]: internal 93 H x 424 W x 550 D - 3 drawers "80" (drawer dimensions [mm]: internal 142 H x 424 W x 550 D
	SSW 912	800 x 520 x 665 (60)	- 6 drawers "80" (drawer dimensions [mm]: internal 93 x 424 x 550

TYPES OF TOPS IN WORKSHOP CUPBOARDS
Top made of plywood 30 mm thick
Top made of plywood 30 mm thick coated with waterproof varnish with increased abrasion resistance
Top made of plywood 30 mm thick coated with corrugated rubber
Metal edges on 3 sides and corrugated rubber

ADDITIONAL EQUIPMENT OPTIONS AVAILABLE IN WORKSHOP CUPBOARDS
Levelling feet (4 pcs.)
4 casters, including 2 casters with brake
Side holder
Base unit 100 mm high

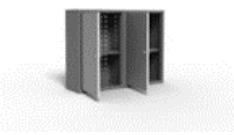
 TYPES OF PARTITIONS for SSW 901, 902, 903, 904, 905, 906 and 909	
PS1/80	For drawers „80”- 45 mm high, distance between partitions 272 mm
PS2/80	For drawers „80”- 45 mm high, distance between partitions 199 mm
PS3/80	For drawers „80”- 45 mm high, distance between partitions 155 mm
PS1/120	For drawers „120”- 95 mm high, distance between partitions 272 mm
PS2/120	For drawers „120”- 95 mm high, distance between partitions 199 mm
PS3/120	For drawers „120”- 95 mm high, distance between partitions 155 mm

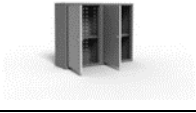
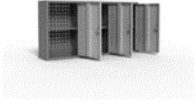
WALL-MOUNTED WORKSHOP CUPBOARDS			
<p>Cupboards are provided with mounting rails, onto which shelves can be placed every 38 mm. Load bearing capacity of each shelf is 20 kg. The doors are locked with a key-lock. Cupboard can be mounted directly on the wall or on the perforated profiles fastened to the workbenches.</p> <p><i>Cupboards are painted with all RAL colours. Delivered cupboards are completely assembled, still shelves need to be mounted.</i></p>			
			
	SKU	DIMENSIONS [mm] H x W x D (WEIGHT [kg])	ADDITIONAL DESCRIPTION
	SWN 400/1	600 x 400 x 215 (8)	1 shelf with no perforations on the door
	SWN 800/2	600 x 800 x 215 (15)	
	SWN 1200/3	600 x 1200 x 215 (21)	

ADDITIONAL EQUIPMENT OPTIONS AVAILABLE IN WALL-MOUNTED CUPBOARDS
Extra shelf
Perforations on 1 door

WORKSHOP CARTS



Drawers in the workshop carts are mounted on the telescopic ball slides (with a stop, which prevents the drawer from falling out of the cabinet) providing smooth and easy extension; they are locked with a master key.

Lockers with hinged doors are locked with a key lock.





Top is made of plywood 30 [mm] thick.



Cart is provided with 2 casters with brake and 2 casters without brake, as well as a holder to move the cart.



Our products are covered by 24-months warranty, whereas the locks are covered by 12-months warranty.

Carts are painted with all RAL colours.



Delivered carts are completely assembled, still shelves and casters need to be mounted.



	SKU	DIMENSIONS [mm] H x W x D	ADDITIONAL DESCRIPTION (WEIGHT [kg])
	WW1	845 x 1240 x 600	The carts frame is made of full profiles 40 x 20 and 1.50 [mm] thick. 3 drawers (drawer dimensions [mm]): external 140 X 479 X 490, internal 127 x 432 x 440 (95) 1 locker with hinged doors. Locker is provided with 1 permanently fixed shelf
	WW2		The carts frame is made of full profiles 40 x 20 and 1.50 [mm] thick. 2 lockers with 3 drawers with the following dimension [mm]: external 140 X 479 X 490, internal 127 x 432 x 440 (107)
	WW3	895 x 1240 x 600	4 drawers 1 locker with hinged doors. Locker is provided with 1 permanently fixed shelf. Weight: (95)
	WW4	900 x 845 x 500	2 drawers "90" (drawer dimensions [mm]): internal 80 H x 424 W x 390 D 1 locker with hinged doors locked with a key lock. External dimensions of the locker [mm] 766 W x 400 H (50)



	<p>WW5</p>		<p>2 drawers "90" on the left (drawer dimensions [mm]: internal 80 H x 424 W x 390 D</p> <p>1 locker with hinged doors on the left, locked with a key lock. External dimensions of the locker [mm] 367 W x 405 H</p> <p>1 drawer on the right "180" (drawer dimensions [mm]: internal 170 H x 336 W x 390 D</p> <p>1 locker with hinged doors on the right, locked with a key lock. External dimensions of the locker [mm] 367 W x 405 H (55)</p>
	<p>WW6</p>		<p>1 locker with hinged doors on the left, locked with a key lock. External dimensions of the locker [mm] 355 W x 635 H</p> <p>4 drawers "90" on the right (drawer dimensions [mm]: internal 80 H x 459 W x 390 D</p> <p>1 drawers "270" on the right (drawer dimensions [mm]: internal 260 H x 459 W x 390 D (67)</p>
	<p>WW7</p>	<p>888 x 960 x 500</p>	<p>1 locker with hinged doors on the left, locked with a key lock. External dimensions of the locker [mm] 355 W x 425 H</p> <p>2 drawers "90" on the left (drawer dimensions [mm]: internal 80 H x 329 W x 390 D</p> <p>3 drawers "90" on the right (drawer dimensions [mm]: internal 80 H x 459 W x 390 D</p> <p>2 drawers "180" on the right (drawer dimensions [mm]: internal 170 H x 459 W x 390 D (68)</p>

	<p>WW8</p>	<p>834 x 820 x 458</p>	<p>2 top drawers "55" (drawer dimensions [mm]: internal 46 H x 705 W x 378 D)</p> <p>1 drawer "55" (drawer dimensions [mm]: internal 46 H x 323 W x 378 D)</p> <p>2 drawers "115" (drawer dimensions [mm]: internal 106 H x 323 W x 378 D)</p> <p>1 drawer "175" (drawer dimensions [mm]: internal 175 H x 323 W x 378 D)</p> <p>1 locker with hinged doors on the right, locked with a key lock. External dimensions of the locker [mm] 374 W x 465 H (66)</p>
	<p>WW9</p>	<p>882 x 919 (841) x 500</p>	<p>The cart is provided with 3 shelves</p>



<p>TYPES OF TOPS IN THE WORKSHOP CARTS (applies to all models)</p>
<p>Top made of plywood coated with waterproof varnish with increased abrasion resistance</p>
<p>Top made of plywood additionally coated with corrugated rubber</p>
<p>Top made of plywood additionally covered with galvanised sheet metal</p>
<p>Top made of plywood covered with inox sheet metal 1.5 mm</p>
<p>Metal edges on 3 sides and corrugated rubber</p>

WORKSHOP CABINETS			
Workshop cabinet with solid structure.			
	Doors are mounted on solid external hinges and are locked with a key lock with a hand wheel, with 3-point locking system.		
	Inside the cabinet is provided with mounting rails to add a wide variety of additional accessories.		
	Our products are covered by 24-months warranty, whereas the locks are covered by 12-months warranty.		
	Cabinets are painted with all RAL colours. Delivered cabinets are completely assembled, shelves need to be mounted.		
	SKU	DIMENSIONS [mm] H x W x D (WEIGHT [kg])	ADDITIONAL DESCRIPTION
With single full hinged door, with reinforcing profile			
	SzP 1D/1050_0	1050 x 537 X 435 (30)	Doors are mounted on 2 solid external hinges No shelves
		1050 x 537 X 500 (32)	
		1050 x 537 X 600 (36)	
	SzP 1D/1050_2	1050 x 537 X 435 (34)	Doors are mounted on 2 solid external hinges 2 shelves inside the cabinets can be mounted on a chosen height by means of steel channel bars.
		1050 x 537 X 500 (38)	
		1050 x 537 X 600 (43)	

	SzP 1D/2000_0	2000 x 537 x 435 (52)	Doors are mounted on 3 solid external hinges No shelves
		2000 x 537 x 500 (56)	
		2000 x 537 x 600 (60)	
	SzP 1D/2000_4	2000 x 537 x 435 (59)	Doors are mounted on 3 solid external hinges. 4 shelves inside the cabinets can be mounted on a chosen height by means of steel channel bars.
		2000 x 537 x 500 (64)	
		2000 x 537 x 600 (70)	
With double full hinged door, with reinforcing profile			
	SzP 2D/1050_0	1050 x 1020 X 435 (47)	Doors are mounted on 2 solid external hinges No shelves
		1050 x 1020 x 500 (51)	





		1050 x 1020 x 600 (56)	
		1050 x 1200 x 500 (56)	
		1050 x 1200 x 600 (61)	
	SzP 2D/1050_2	1050 x 1020 X 435 (57)	Doors are mounted on 2 solid external hinges 2 shelves inside the cabinets can be mounted on a chosen height by means of steel channel bars.
		1050 x 1020 x 500 (61)	
		1050 x 1020 x 600 (68)	
		1050 x 1200 x 500 (69)	
		1050 x 1200 x 600 (76)	
	SzP 2D/2000_0	2000 x 1020 X 435 (82)	Doors are mounted on 3 solid external hinges No shelves
		2000 x 1020 X 500 (85)	

		2000 x 1020 X 600 (90)	
		2000 x 1200 X 500 (93)	
		2000 x 1200 X 600 (100)	
	SzP 2D/2000_4	2000 x 1020 X 435 (102)	<p>Doors are mounted on 3 solid external hinges.</p> <p>4 shelves inside the cabinets can be mounted on a chosen height by means of steel channel bars.</p>
		2000 x 1020 X 500 (107)	
		2000 x 1020 X 600 (116)	
		2000 x 1200 X 500 (123)	

		2000 x 1200 X 600 (132)	
With double hinged doors, with plexiglass insert			
	SzP 2P/1050_0	1050 x 1020 X 435 (48)	Doors are mounted on 2 solid external hinges No shelves
		1050 x 1020 x 500 (52)	
		1050 x 1020 x 600 (57)	
		1050 x 1200 x 500 (57)	
		1050 x 1200 x 600 (62)	
	SzP 2P/1050_2	1050 x 1020 X 435 (58)	Doors are mounted on 2 solid external hinges. 2 shelves inside the cabinets can be mounted on a chosen height by means of steel channel bars.

		1050 x 1020 x 500 (63)	
		1050 x 1020 x 600 (70)	
		1050 x 1200 x 500 (71)	
		1050 x 1200 x 600 (78)	
	SzP 2P/2000_0	2000 x 1020 X 435 (83)	Doors are mounted on 3 solid external hinges No shelves
		2000 x 1020 X 500 (86)	
		2000 x 1020 X 600 (91)	

		2000 x 1200 X 500 (94)	
		2000 x 1200 X 600 (101)	
	SzP 2P/2000_4	2000 x 1020 X 435 (103)	<p>Doors are mounted on 3 solid external hinges.</p> <p>4 shelves inside the cabinets can be mounted on a chosen height by means of steel channel bars.</p>
		2000 x 1020 X 500 (108)	
		2000 x 1020 X 600 (117)	
		2000 x 1200 X 500 (124)	
		2000 x 1200 X 600 (133)	
With roller shutter doors			

	SzP 2Z/1050_0	1050 x 1200 x 450	Doors are made of slidable PVC roller shutter, which conceals along the side walls. Doors are locked with a key-lock. (51)
	SzP 2Z/1050_2		Doors are made of slidable PVC roller shutter, which conceals along the side walls. Doors are locked with a key-lock. 2 shelves inside the cabinets can be mounted on a chosen height by means of steel channel bars. (60)
	SzP 2Z/2000_0	2000 x 1200 x 450	Doors are made of slidable PVC roller shutter, which conceals along the side walls. Doors are locked with a key-lock (91)
	SzP 2Z/2000_4		Doors are made of slidable PVC roller shutter, which conceals along the side walls. Doors are locked with a key-lock. 2 shelves inside the cabinets can be mounted on a chosen height by means of steel channel bars. (115)

ADDITIONAL EQUIPMENT OPTIONS AVAILABLE IN THE WORKSHOP CABINETS	Dimensions H x W x D [mm]
Perforated tool panel on the back wall of the cabinet 450 mm high	450 x 970 // 450 x 1170
Pull-out shelf	40 x 921 x 390
Shelf	25 x 1008 x 352
Shelf with an edge for containers with chemical agents	40 x 1008 x 355
Drawer 100 high	external 97 X 936 X 549, internal 85 x 919 x 527
Drawer 200	external 197 X 936 X 549, internal 185 x 919 x 527
Pull-out frame for suspension files	40 x 921 x 390
Collecting tray with a flange	80 x 930 x 367
Top made of laminated plate 25 mm thick	For cabinets 1050 high
Top made of plywood 30 mm thick	80 x 930 x 367

CUSTOM-MADE WORKSHOP CABINETS

Cabinets are provided with PP containers.

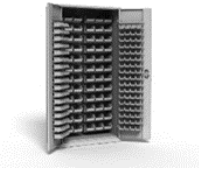



Our products are covered by 24-months warranty, whereas the locks are covered by 12-months warranty.





Cabinets painted with all RAL colours.



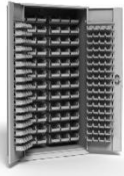

Delivered cabinets are completely assembled, still shelves need to be mounted.



	SKU	DIMENSIONS [mm] H x W x D (WEIGHT [kg])	ADDITIONAL DESCRIPTION
Service workshop cabinet			
	SzP/0-RZ-007	1950 x 1020 x 535 (160)	<p>1. TOP SECTION with a locker provided with double hinged door. Doors are provided with internal hinges, giving free access to the furniture interior. Perforated panels are mounted on both doors and back of the cabinet, to mount additional accessories. A shelf adjustable every 30 - 40 mm with a minimum load bearing capacity of 50 kg is mounted inside the locker. Doors are locked with a key lock, with 3-point locking system</p> <p>2. MIDDLE SECTION with:</p> <ul style="list-style-type: none"> - a locker with single hinged door, with the following external dimensions [W x H] 390 mm x 626 mm. Doors are locked with a key lock, with 1-point locking system. The locker has 1 permanently fixed shelf. - 3 drawers with useful dimensions [W x H x D] 536 mm x 75 mm x 500 mm and 2 drawers with useful dimensions [W x H x D] 536 mm x 165 mm x 500 mm. All drawers are locked with a single master key and are provided with a special system, so that only one drawer can be open at a time. <p>3. BOTTOM SECTION with 1 drawer with useful dimensions [W x H x D] 955 mm x 165 mm x 450 mm. Drawer is locked with a key-lock.</p> <p>The cabinet is provided with levelling feet, is delivered completely assembled, only shelf and additional accessories need to be mounted</p>





Workshop cabinet with 5 adjustable shelves, 3 drawers, 1 panel and 14 containers			
	<p>SZP/MX43N 0/2D00/13S S</p>	<p>2000 x 1020 x 435 (162)</p>	<p>Workshop cabinet with massive structure having full doors and reinforcing profile.</p> <p>Doors are mounted on 3 solid external hinges and are locked with a key lock with a hand wheel, with 3-point locking system.</p> <p>Mounting rails inside the cabinet are suitable to mount:</p> <ul style="list-style-type: none"> - 3 adjustable narrow shelves with the following dimensions 978 mm W x 230 mm D, each, - 2 adjustable deep shelves with the following dimensions 978 mm W x 373 mm D, each, - 2 drawers "100" with the useful dimensions: 78 mm H x 919 mm W x 362 mm D - 1 drawer "200" with the useful dimensions 178 mm H x 919 mm W x 362 mm D. <p>Drawers are mounted on the telescopic ball slides (with a stop, which prevents the drawer from falling out of the cabinet) providing smooth and easy extension.</p> <p>Left door is provided with 4 mounting rails for workshop containers made of PP arranged as follows:</p> <ul style="list-style-type: none"> - 2 rows with 3 containers PW 4 with the following dimensions (D x W x H) 157x101x74 [mm] - altogether 6 pcs. - 2 rows with 4 containers PW 5 with the following dimensions (D x W x H) 119x77x 56 [mm] on each door - altogether 8 pcs. <p>Perforated panel of 948 mm high x 345 mm wide for mounting hooks and other mounts is located on the right door.</p>

Workshop cabinet with 11 adjustable shelves and 134 containers			
	<p>SZP/MX43N0/2D 00/11PUS</p>	<p>2000 x 1020 x 435 (130)</p>	<p>Workshop cabinet with massive structure having full doors and reinforcing profile.</p> <p>Doors are mounted on 3 solid external hinges and are locked with a key lock with a hand wheel, with 3-point locking system.</p> <p>Inside the cabinet there are mounting rails, on which by means of steel channel bars 11 adjustable, galvanised (not painted) shelves can be mounted.</p> <p>Containers made of PP are configured on the said shelves as follows:</p> <ul style="list-style-type: none"> - 3 rows with 8 containers PW 4 with the following dimensions (D x W x H) 157 x 101 x 74 [mm]- altogether 24 pcs. (for instance in blue colour) - 4 rows with 6 containers PW 3 with the following dimensions (D x W x H) 224 x 144 x 108 [mm]- altogether 24 pcs. (for instance in red colour) - 4 rows with 4 containers PW 2 with the following dimensions (D x W x H) 314 x 202 x 148 [mm] altogether 16 pcs. (for instance in red colour) <p>Each door is provided with 10 mounting rails to mount workshop containers as follows:</p> <ul style="list-style-type: none"> - 5 rows with 3 containers PW 4 with the following dimensions (D x W x H) 157x101x74 [mm] on each door - altogether 30 pcs. on both doors (for instance in blue colour) - 5 rows with 4 containers PW 5 with the following dimensions (D x W x H) 119x77x56 [mm] on each door - altogether 40 pcs. on both doors (for instance in blue colour)

Workshop cabinets with 200 containers			
	SZP/MX43N0/2D 00/UPS	2000 x 1020 x 435 (140)	<p>Workshop cabinet with massive structure having full doors and reinforcing profile.</p> <p>Doors are mounted on 3 solid external hinges and are locked with a key lock with a hand wheel, with 3-point locking system.</p> <p>Inside the cabinet there are 12 rows of mounting rails, whereas each row is provided with 6 pcs. of PP containers PW 3 with the following dimensions 224 deep x 144 wide x 108 high [mm], altogether 72 pcs. of containers,</p> <p>On each door there are 16 rows of mounting rails, whereas each row is provided with 4 pcs. of PP containers PW 5 with the following dimensions 119 deep x 77 wide x 56 high [mm]- altogether 64 pcs. of containers on each door</p>
Workshop cabinet with 2 panels, 2 adjustable shelves and 20 containers			
	SZP/MX43N0/2D 00/14SS	2000 x 1020 x 435 (93)	<p>The main compartment is provided with:</p> <ul style="list-style-type: none"> - 2 tools panels, each is 450 mm high, - 2 adjustable shelves, - 2 mounting rails for PW3 containers, - 12 pcs. of PW3 containers (1.6 l) - 8 pcs. of PW2 containers (4 l) to be placed on the shelves. <p>Doors are mounted on 3 solid external hinges and are locked with a key lock with a hand wheel, with 3-point locking system.</p>
Workshop cabinet with 6 adjustable shelves and 28 containers			
	SZP/MX43N0/2D 00/15SS	2000 x 1020 x 435 (115)	<p>The main compartment is provided with:</p> <ul style="list-style-type: none"> - 6 adjustable shelves - 28 pcs. of PW2 containers (4 l) <p>Doors are mounted on 3 solid external hinges and are locked with a key lock with a hand wheel, with 3-point locking system.</p>
Workshop cabinet with 1 panel, 2 adjustable shelves and 6 drawers			
	SZP/MX50N0/2D 00/16SS	2000 x 1020 x 500 (115)	<p>The main compartment is provided with:</p> <ul style="list-style-type: none"> s- 1 tools panel, - 2 adjustable shelves, - 4 drawers 80 mm high, - 2 drawers 150 mm high. <p>Doors are mounted on 3 solid external hinges and are locked with a key lock with a hand wheel, with 3-point locking system.</p>

Workshop cabinet with 2 panels, 1 adjustable shelf, 6 drawers and 8 containers			
	SZP/MX50N0/2D 00/17SS	2000 x 1020 x 500 (110)	<p>The main compartment is provided with:</p> <ul style="list-style-type: none"> - 2 tools panels, - 1 adjustable shelf, - 8 pcs. of PW2 containers (4 l), - 4 drawers 80 mm high, - 2 drawers 150 mm high. <p>Doors are mounted on 3 solid external hinges and are locked with a key lock with a hand wheel, with 3-point locking system.</p>
Workshop cabinets with 60 containers			
	SZP/MX43N0/2D 00/18SS	2000 x 1020 x 435	<ul style="list-style-type: none"> - 11 rows of mounting rails, - 16 pcs. of PW4 containers of 0.5 l capacity - 8 pcs. of PW6 containers of 0.9 l capacity - 24 pcs. of PW3 containers of 1.6 l capacity - 12 pcs. of PW2 containers of 4 l capacity. <p>Doors are mounted on 3 solid external hinges and are locked with a key lock with a hand wheel, with 3-point locking system.</p>
Workshop cabinets with 144 containers			
	SZP/MX43N0/2D 0R/19SS	2000 x 1020 x 435	<p>The main compartment is provided with:</p> <ul style="list-style-type: none"> - 13 rows of mounting rails, - 24 pcs. of PW4 containers of 0.5 l capacity - 8 pcs. of PW6 containers of 0.9 l capacity - 24 pcs. of PW3 containers of 1.6 l capacity - 16 pcs. of PW2 containers of 4 l capacity. <p>On each door there are 9 rows of mounting rails, whereas each row is provided with 4 pcs. of PW 5 containers of 0.2 l capacity, which altogether makes 36 pcs. of containers on each door.</p> <p>Doors are mounted on 3 solid external hinges and are locked with a key lock with a hand wheel, with 3-point locking system.</p>
Workshop cabinet with 5 adjustable shelves, 2 drawers 100H and 2 drawers 200H			
	SZP/MX43N0/2D 00/05SS	2000 x 1020 x 435	<p>Mounting rails inside the cabinet are suitable to mount:</p> <ul style="list-style-type: none"> - 5 pcs. of adjustable shelves with the following dimensions: 978 mm W x 373 mm D, each, - 2 drawers "100" with the useful dimensions: 78 mm H x 919 mm W x 362 mm D - 2 drawers "200" with the useful dimensions 178 mm H x 919 mm W x 362 mm D.

	SZP/MX50N0/2D 00/05SS	2000 x 1020 x 500	<p>Drawers are mounted on the telescopic ball slides (with a stop, which prevents the drawer from falling out of the cabinet) providing smooth and easy extension.</p> <p>Doors are mounted on 3 solid external hinges and are locked with a key lock with a hand wheel, with 3-point locking system.</p>
Workshop cabinet with 2 panels, 2 shelves, 3 drawers and 70 containers			
	SZP/MX43N0/2D 00/23SS	2000 x 1020 x 435	<p>Mounting rails inside the cabinet are suitable to mount (by means of steel channel bars):</p> <ul style="list-style-type: none"> - 2 tools panels, - 1 adjustable shelf, - 1 permanently fixed shelf, - 2 drawers, each is 100 mm high - 1 drawer 200 mm high.
	SZP/MX50N0/2D 00/23SS	2000 x 1020 x 500	<p>Each door is provided with 10 rows of mounting rails:</p> <ul style="list-style-type: none"> - 5 rows with PW4 containers, 3 pcs. of containers in each row (altogether 15 pcs. of PW4 containers on each door), - 5 rows with PW5 containers, 4 pcs. of containers in each row (altogether 20 pcs. of PW4 containers on each door) <p>Doors are mounted on 3 solid external hinges and are locked with a key lock with a hand wheel, with 3-point locking system.</p>
Workshop cabinet with 1 panel, 3 adjustable shelves and 4 drawers 100H			
	SZP/MX43N0/2D 00/24SS	2000 x 1020 x 435	<p>Mounting rails inside the cabinet are suitable to mount (by means of steel channel bars):</p> <ul style="list-style-type: none"> - 1 tools panel, - 3 adjustable shelves, - 4 drawers, each is 100 mm high.
	SZP/MX50N0/2D 00/24SS	2000 x 1020 x 500	<p>Doors are mounted on 3 solid external hinges and are locked with a key lock with a hand wheel, with 3-point locking system.</p>
Workshop cabinet with 2 adjustable shelves, 1 permanently fixed shelf, 2 drawers 100H and 2 drawers 200 mm H			

	SZP/MX43N0/2D 00/25SS	2000 x 1020 x 435	<p>Mounting rails inside the cabinet are suitable to mount (by means of steel channel bars):</p> <ul style="list-style-type: none"> - 2 adjustable shelves, - 1 permanently fixed shelf (shelf for drawers) - 2 drawers, each is 100 mm high. - 2 drawers, each is 200 mm high. <p>Doors are mounted on 3 solid external hinges and are locked with a key lock with a hand wheel, with 3-point locking system.</p>
	SZP/MX50N0/2D 00/25SS	2000 x 1020 x 500	
Workshop cabinet with 2 adjustable shelves, 1 permanently fixed shelf, 2 drawers 100H and 1 drawer 200 mm H			
	SZP/MX43N0/2D 00/03SS	2000 x 1020 x 435	<p>Mounting rails inside the cabinet are suitable to mount (by means of steel channel bars):</p> <ul style="list-style-type: none"> - 2 adjustable shelves, - 1 permanently fixed shelf (shelf for drawers) - 2 drawers, each is 100 mm high, - 1 drawer 200 mm high. <p>Doors are mounted on 3 solid external hinges and are locked with a key lock with a hand wheel, with 3-point locking system.</p>
	SZP/MX50N0/2D 00/03SS	2000 x 1020 x 500	
Workshop cabinet with 1 panel, 2 adjustable shelves, 1 permanently fixed shelf, 2 drawers 100H and 1 drawer 200 mm H			
	SZP/MX43N0/2D 00/12SS	2000 x 1020 x 435	<p>Mounting rails inside the cabinet are suitable to mount (by means of steel channel bars):</p> <ul style="list-style-type: none"> - 1 tools panel, - 2 adjustable shelves, - 1 permanently fixed shelf (shelf for drawers) - 2 drawers, each is 100 mm high, - 1 drawer 200 mm high. <p>Doors are mounted on 3 solid external hinges and are locked with a key lock with a hand wheel, with 3-point locking system.</p>
	SZP/MX50N0/2D 00/12SS	2000 x 1020 x 500	
Workshop cabinet with 2 drawers 200 mm H and 14 drawers 100 mm H			
	SZP/MX43N0/2D 00/2S14S	2000 x 1020x 435	<p>Panels inside the cabinet are suitable to mount:</p> <ul style="list-style-type: none"> - 2 drawers, each is 200 mm high, - 14 drawers, each is 100 mm high,. <p>Doors are mounted on 3 solid external hinges and are locked with a key lock with a hand wheel, with 3-point locking system.</p>
	SZP/MX50N0/2D 00/2S14S	2000 x 1020 x 500	

	SZP/MX43N0/2 DOR/26SS	2000 x 1020 x 435	<p>Mounting rails inside the cabinet are suitable to mount (by means of steel channel bars):</p> <ul style="list-style-type: none"> - 1 tools panel, - 2 adjustable shelves, - 1 permanently fixed shelf (shelf for drawers) - 4 drawers, each is 80 mm high, - 2 drawers 150 mm high. <p>Doors are mounted on 3 solid external hinges and are locked with a key lock with a hand wheel, with 3-point locking system.</p>
	SZP/MX50N0/2 DOR/26SS	2000 x 1020 x 500	

WORKSHOP CABINETS FOR CHEMICAL SUBSTANCES





Our products are covered by 24-months warranty, whereas the locks are covered by 12-months warranty.

Cabinets painted with all RAL colours.

Delivered cabinets are completely assembled, still shelves need to be mounted.

	SKU	DIMENSIONS [mm] H x W x D (WEIGHT kg)]	ADDITIONAL DESCRIPTION
Workshop cabinet for chemical substances with collecting tray, shelves and connection port			
	SZP/MX43N0/2D 00/4CWS	2000 x 1020 x 435	<p>Doors are provided with openings to draw the outside air into the cabinet.</p> <p>Mounting rails inside the cabinet are suitable to mount (by means of steel channel bars):</p> <ul style="list-style-type: none"> - 4 adjustable full shelves with edges on all sides. <p>The cabinet is provided with a collecting tray.</p>
	SZP/MX50N0/2D 00/4CWS	2000 x 1020 x 500	
	SZP/MX60N0/2D 00/4CWS	2000 x 1020 x 600	<p>Connection port provided in the top section of the cabinet is suitable to connect external ventilation system to the cabinet.</p>

			<p>Doors are mounted on 3 solid external hinges and are locked with a key lock with a hand wheel, with 3-point locking system.</p>
<p>Workshop cabinet for chemical substances with zinc plated shelves</p>			
	<p>WK/INN/TECH/O -LG-021</p>	<p>2000 x 1000 x 500</p>	<p>Workshop cabinet for chemical and flammable substances.</p> <p>Mounting rails inside the cabinet are suitable to mount (by means of steel channel bars): - 4 adjustable full zinc plated shelves with edges on all sides.</p> <p>The cabinet is provided with a collecting clay.</p> <p>Doors are mounted on 3 solid external hinges and are locked with a key lock with a hand wheel, with 3-point locking system.</p> <p>Colors: Casing + shelves RAL 7035 Doors RAL 1003</p>
	<p>WK/INN/TECH/O -BG-039</p>	<p>1050 x 1000 x 500</p>	<p>Workshop cabinet for chemical and flammable substances.</p> <p>Mounting rails inside the cabinet are suitable to mount (by means of steel channel bars): - 2 adjustable full zinc plated shelves with edges on all sides.</p> <p>The cabinet is provided with a collecting clay.</p> <p>Doors are mounted on 3 solid external hinges and are locked with a key lock with a hand wheel, with 3-point locking system.</p> <p>Colors: Casing + shelves RAL 7035 Doors RAL 1003</p>

STANDS FOR WORKSHOP CONTAINERS

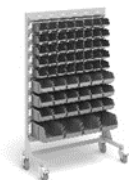



Reinforced metal frame makes the stands for containers particularly stable and resistant to heavy loads. The frame is made of full steel profiles 20 x 40, which are 1.50 [mm] thick, other parts of the frame is made of 2.0 [mm] thick metal sheet. Metal hooks, onto which durable, polypropylene containers of different size are hung, are screwed to the frame.

Containers are made of durable polypropylene, which make them impact resistant, as well as resistant to most chemical compounds, acids and machine oil. Containers can be provided with labels and compartments.

Stands are single- or double-sided, and are equipped with levelling feet. Optionally stands can be provided with 4 wheels of 100 mm diameter (front wheels with brakes) to make their transportation easier.

Our products are covered by 24-months warranty, whereas the locks are covered by 12-months warranty.









Stands can be painted with all RAL colours.
They need to be assembled.









	SKU	DIMENSIONS [mm] H x W x D (WEIGHT [kg])	ADDITIONAL DESCRIPTION
Single-sided workshop stands			
	SWJ_1	1400 x 940 x 395	40 containers of PW 4 type - 0.5 l capacity, D157 x W101 x H74 [mm] - are hung in rows I-V. . 18 containers of PW 3 type - 1.6 l capacity, D224 x W144 x H108 [mm] - are hung in rows VI-VIII . 4 containers of PW 2 type - 4 l capacity, D314 x W202 x H148 [mm] - are hung in row IX. .
	SWJ_2	1560 x 940 x 395	16 containers of PW 4 type - 0.5 l capacity, D157 x W101 x H74 [mm] - are hung in rows I-II. . 24 containers of PW 3 type - 1.6 l capacity, D224 x W144 x H108 [mm] - are hung in rows III-VI . 12 containers of PW 2 type - 4 l capacity, D314 x W202 x H148 [mm] - are hung in rows VII-IX .
	SWJ_3	1540 x 940 x 395	16 containers of PW 4 type - 0.5 l capacity, D157 x W101 x H74 [mm] - are hung in rows I-II. . 48 containers of PW 3 type - 1.6 l capacity, D224 x W144 x H108 [mm] - are hung in rows III-X .







Double-sided workshop stands			
	SWD_1	1400 x 940 x 395	<p>On both sides:</p> <ul style="list-style-type: none"> - 40 containers of PW 4 type - 0.5 l capacity, D157 x W101 x H74 [mm] - are hung in rows I-V. - altogether 80 containers of PW 4 type. - 18 containers of PW 3 type - 1.6 l capacity, D224 x W144 x H108 [mm] - are hung in rows VI-VIII - altogether 36 containers of PW 3 type. - 4 containers of PW 2 type - 4 l capacity, D314 x W202 x H148 [mm] - are hung in row IX. - altogether 8 containers of PW 3 type.

ADDITIONAL EQUIPMENT OPTIONS AVAILABLE IN STANDS FOR WORKSHOP CONTAINERS

4 casters, including 2 casters with a brake

TYPES OF MOUNTS FOR THE WORKSHOP CABINETS	
	Mount ACC1 - galvanised for tubular spanners
	Mount ACC2 - galvanised for open ended spanners
	Mount ACC3 - galvanised for screwdrivers
	Mount ACC4 - galvanised for drills
	Mount ACC7 - galvanised universal 100 mm type "C"
	Mount ACC5 - galvanised universal 160 mm type "C"
	Mount ACC6 - galvanised universal 200 mm type "C"
	Mount ACC8 - galvanised universal 100 mm type "UW"
	Mount ACC10 - galvanised universal 150 mm type "UW"

	<p>Mount ACC9 - galvanized universal 200 mm type "UW"</p>
	<p>Mount ACC11- galvanized universal</p>
	<p>Mount ACC12 - galvanized universal 100 mm type "L"</p>
	<p>Mount ACC13 - galvanized universal 150 mm type "L"</p>
	<p>Mount ACC14 - galvanized universal 200 mm type "L"</p>
	<p>Mount ACC15 - galvanized universal single type "H"</p>
	<p>Mount ACC16 - galvanized universal double type "H"</p>
	<p>Mount ACC17 for documents, to be hung on perforated boards 83 H x 125 W x 15 D</p>

	<p>Galvanised mount ACC18 to mount plastic container of "IV" type</p>
<p>TYPES OF CONTAINERS FOR THE WORKSHOP FURNITURE</p>	
	<p>PW1- container of approx. 12 dm³ capacity with the following external dimensions (I) 440 x 285 x 210 [mm] (D x W x H)</p>
	<p>PW2- container of approx. 4 dm³ capacity with the following external dimensions (II) 314 x 202 x 148 [mm] (D x W x H)</p>
	<p>PW3- container of approx. 1.6 dm³ capacity with the following external dimensions (D x W x H) 224 x 144 x 108 [mm]</p>
	<p>PW4 - container of approx. 0.5 dm³ capacity with the following external dimensions (D x W x H) 157 x 101 x 74 [mm]</p>
	<p>PW5 - container of approx. 0.2 dm³ capacity with the following external dimensions (D x W x H) 119 x 77 x 56 [mm]</p>
	<p>PW6 - container of approx. 0.9 dm³ capacity with the following external dimensions (D x W x H) 140 x 203 x 74 [mm]</p>

COMPUTER + COMPUTER WITH LCD MONITOR CABINETS



- The cabinet is provided with 3 separately locked sections:
1. section for monitor
 2. a drawer for a keyboard and a computer mouse,
 3. a locker with a drawer for central unit and a place for printer.
- Each section is separately locked with a key-lock.



The cabinet is provided with a power strip and cables.
Back wall is provided with 2 openings (in top and bottom part of the cabinet) for power leads.
Vents are provided on the side wall.



Standard computer cabinet can be optionally custom made to meet the client's needs; we also offer a mounting frame for touch screen, as specified in the client's instructions.

Our products are covered by 24-months warranty, whereas the locks are covered by 12-months warranty.

Cabinets painted with all RAL colours.

Delivered cabinets are completely assembled.

	SKU	DIMENSIONS [mm] H x W x D (WEIGHT [kg])	ADDITIONAL DESCRIPTION
	SzK1 LCD	1496 (1624 with casters; 1596 with stands) x 605 x 635 (80)	<ul style="list-style-type: none"> - top section of the cabinet with plexiglass or glass front (anti-reflection acrylic glass) and a flap is suitable for LCD monitor, according to VESA standard (17-22 inches). Maximum opening dimensions in the door: 495 mm wide x 614 mm high), - perforated wall in the top section provides suitable ventilation in the compartment with the monitor, - a monitor is fastened to the cabinet by means of a mounting plate, which is first screwed to the monitor, and then mounted on the perforated wall in the top section, - a drawer for a keyboard and a computer mouse (a drawer is 82 mm high) and a bottom retractable shelf are both mounted on the telescopic ball slides (with a stop, which prevents the drawer/shelf from falling out of the cabinet) providing smooth and easy extension. - a shelf in the bottom section of the cabinet can be mounted on a chosen height.
	SzK2 LCD	1756 x 647 x 634	<p>The cabinet is provided with 3 separately locked sections:</p> <ol style="list-style-type: none"> 1. top section with a plexiglass front for a monitor: <ul style="list-style-type: none"> - casing (652 H x 580 W x 300 D) is suitable to place LCD monitor up to 23 inches, 2. a drawer for a keyboard and a computer mouse: <ul style="list-style-type: none"> - fully extendible drawer is mounted on the telescopic ball slides (with a stop, which prevents the drawer from falling out of the cabinet), 3. bottom locker with a shelf (adjustable every 25 mm) for a central unit and a place for printer.

			<p>Each section is separately locked with a key-lock.</p> <p>The cabinet is provided with 1 opening in the bottom of a monitor casing and 1 opening in the back wall of the furniture, both designed for power leads.</p> <p>The cabinet is provided with 4 screwed stands M10.</p>
	SzK3 LCD	<p>1496 (1624 with casters; 1596 with stands) x 605 x 635 (80)</p>	<ul style="list-style-type: none"> - top section of the cabinet with plexiglass or glass front (anti-reflection acrylic glass) and a flap is suitable for LCD monitor, according to VESA standard (17-22 inches). Maximum opening in the door: 495 mm wide x 614 mm high), - perforated wall in the top section provides suitable ventilation in the compartment with the monitor, - monitor is fastened to the cabinet by means of a mounting plate, which is first screwed to the monitor, and then mounted on the perforated wall in the top section, - a drawer for a keyboard and a computer mouse and a bottom retractable shelf are both mounted on the telescopic ball slides (with a stop, which prevents the drawer/shelf from falling out of the cabinet) providing smooth and easy extension. - a shelf is the bottom section of the cabinet can be mounted on a chosen height.
	SzK1	<p>1570 (1698 with casters; 1580 with stands) x 605 x 635 (70)</p>	<ul style="list-style-type: none"> - top section of the cabinet with plexiglass or glass front (anti-reflection acrylic glass) is suitable to place LCD monitor up to 22 inches, - a drawer for a keyboard and a computer mouse (a drawer is 77 mm high) and a bottom retractable shelf are both mounted on the telescopic ball slides (with a stop, which prevents the drawer/shelf from falling out of the cabinet) providing smooth and easy extension. - a shelf is the bottom section of the cabinet can be mounted on a chosen height.

ADDITIONAL EQUIPMENT OPTIONS AVAILABLE IN THE COMPUTER CABINETS
Levelling feet (4 pcs.)
Stands 100 mm high (4 pcs.)
4 casters, including 2 casters with brake
Small service (revision) door locked with a key lock and provided with plexiglass insert mounted on the front or side wall of the cabinet (300 mm H x 300 mm W).
Cabinets seal (rubber gaskets and brush seals) with cable passages.
Adjustment of the top door of the cabinet provided with a rubber gasket to house LCD touch screen (does not apply to SzK1)
5-socket power strip
A fan with a filter to cool the cabinet's interior (drawing out the air)
A handle for cabinet transportation
Extra shelf for storing documents (does not apply to SzK1)

HIGH LAPTOP CABINETS



In multi-tier laptop cabinets, every compartment can be used separately, which is why they are best suited to hotels, conference rooms, or training facilities. Each computer is placed in a separate, ventilated compartment, which can be also fitted with a power socket.

Standard equipment includes:



- welded structure of the laptop cabinets is made of full profiles,- each compartment is locked with a change key with 1-point locking, being a part of master keying system,
- each compartment door is provided with a place for an identifier,
- to ensure the best possible airflow, cabinets are provided with ventilation holes inside the compartments and on the back wall,
- openings in the back and side walls can be used to mount the cabinet on a wall, which eliminates the risk of falling down.

Cabinets come in two versions: a variant without electrical connections and a version that can be used at ~230V, which can simultaneously charge the batteries of all devices stored inside.

Our products are covered by 24-months warranty, whereas the locks are covered by 12-months warranty.

Cabinets painted with all RAL colours.

Delivered cabinets are completely assembled.

	SKU	DIMENSIONS [mm] H x W x D (WEIGHT [kg])	ADDITIONAL DESCRIPTION
	SzLP 10K1	1800 x 400 x 500 (58)	No power supply
	SzLP 10K2	1800 x 920 x 500 (115)	No power supply

ADDITIONAL EQUIPMENT OPTIONS AVAILABLE IN THE LAPTOP CABINETS

Levelling feet (4 pcs.)

Stands 100 mm high (4 pcs.)

4 casters, including 2 casters with brake

Coded lock with 1-point locking (1 pc.)

10-socket power strip, which powers each compartment separately (does not apply to SzL 10K2)

Door stop (1 pc.)

LAPTOP CARTS



Low cabinets with hinged doors and carts for laptops, tablets, mobiles, etc.

Low cabinets and carts are designed for safe storing and charging of electrical devices.

They are offered as 1-, 2- or 3-column cabinets; the number of power strips corresponds the number of columns.





- massive structure with double hinged doors,
- doors are mounted on solid external hinges and are locked with a key lock with a hand wheel, with 3-point locking system,
- the cabinet is provided with one 230 V 10A power socket; main switch is placed on the side wall of the furniture,
- power strips (whose number corresponds to the number of columns) are placed inside the cabinet,
- inside the cabinet there are multi-tier compartments, each of which has a dedicated separate socket on the power strip, hence all devices stored in the cabinet can be simultaneously charged,
- a top made of laminated plate in grey colour (25 mm thick) is mounted on the cabinet,
- handles for cabinet transportation are located on both side walls,
- the cabinet is provided with 4 casters, 2 of which have brakes,
- side walls of the cabinet are provided with ventilation openings to cool electronic devices stored inside.

All carts are granted declaration of conformity with 2001/95/EC Directive on general product safety.

Our products are covered by 24-months warranty.

Cabinets painted with all RAL colours.

Delivered cabinets are completely assembled, still casters need to be mounted.

	SKU	DIMENSIONS [mm] H x W x D (WEIGHT [kg])	ADDITIONAL DESCRIPTION
16 – compartment			
	WLPZ 8K2	1085 x 920 x 550 (87)	2 columns with 8 compartments each, 2 power strips with 8 sockets each
20 – compartment			
	WLPZ 10K2	1250 x 920 x 550 (100)	2 columns with 10 compartments each, 2 power strips with 10 sockets each
26 – compartment			
2 – column 	WLPZ 13K2	1540 x 920 x 550 (125)	2 columns with 13 compartments each, 2 power strips with 13 sockets each
30 – compartment			
3 – column 	WLPZ 10K3	1250 x 1310 x 550 (165)	3 columns with 10 compartments each, 3 power strips with 10 sockets each EC Declaration of Conformity Maximum power 3680W

ADDITIONAL EQUIPMENT OPTIONS AVAILABLE IN THE LAPTOP CARTS

Stands 100 mm high

Coded lock with 3-point locking

RACKS





Our offer includes also racks assembled with screws or catches.

Our products are covered by 24-months warranty, whereas the locks are covered by 12-months warranty.

Racks painted with all RAL colours.



Delivered racks are completely assembled, still shelves need to be mounted.



	SKU	DIMENSIO NS [mm] H x W x D of the rack/ D of the shelf (WEIGHT [kg])	ADDITIONAL DESCRIPTION
Racks assembled with screws			
	RGŁ SK/2000/410 /5P	2000 x 1020 x 410/ 390 (32)	<ul style="list-style-type: none"> - perforated stands made of sheet metal 2 mm thick with the following dimensions 58 mm x 45 mm. - shelves (1000 mm wide) made of sheet metal 1 mm thick - 5 shelves, each of maximum load bearing capacity 100 kg - shelves are fastened to the stands by means of 3 screws on each corner - a rack is provided with a set of angle braces, in order to increase its stability <p>Maximum allowable load on the completely assembled rack with angle braces (regardless of the number and types of shelves) - 600 kg</p>
	RGŁ SK/2000/510 /5P	2000 x 1020 x 510/ 490 (37)	
	RGŁ SK/2000/610 /5P	2000 x 1020 x 610/ 590 (40)	
	RGŁ SK/2500/410 /6P	2500 x 1020 x 410/ 390 (36)	<ul style="list-style-type: none"> - perforated stands made of sheet metal 2 mm thick with the following dimensions 58 mm x 45 mm. - shelves (1000 mm wide) made of sheet metal 1 mm thick - 6 shelves, each of maximum load bearing capacity 100 kg - shelves are fastened to the stands by means of 3 screws on each corner - a rack is provided with a set of angle braces, in order to increase its stability <p>Maximum allowable load on the completely assembled rack with angle braces (regardless of the number and types of shelves) - 600 kg</p>
	RGŁ SK/2500/510 /6P	2500 x 1020 x 510/ 490 (40)	
	RGŁ SK/2500/610 /6P	2500 x 1020 x 610/ 590 (44)	
Racks assembled with catches			
	RGŁ ZP/2000/392 /5P	2000 x 1070 x 392/ 390 (32)	<ul style="list-style-type: none"> - Simple assembly without screws - perforated frame/stands with rectangular cross-section made of sheet metal 1 mm thick with the following dimensions 30 mm x 35 mm - shelves (1000 mm wide) made of sheet metal 1 mm thick

	RGŁ ZP/2000/492 /5P	2000 x 1070 x 492/ 490 (37)	<ul style="list-style-type: none"> - 5 shelves, each of maximum load bearing capacity 100 kg - shelves mounted by means of steel hooks - shelves adjustable every 25 mm - a rack is provided with a set of angle braces, in order to increase its stability - racks can be coupled by means of common angle braces <p>Maximum allowable load on the completely assembled rack with angle braces (regardless of the number and types of shelves) - 600 kg</p>
	RGŁ ZP/2000/592 /5P	2000 x 1070 x 592/ 590 (50)	
	RGŁ ZP/2500/392 /6P	2500 x 1070 x 392/ 390 (35)	<ul style="list-style-type: none"> - Simple assembly without screws - perforated frame/stands with rectangular cross-section made of sheet metal 1 mm thick with the following dimensions 30 mm x 35 mm - shelves (1000 mm wide) made of sheet metal 1 mm thick - 6 shelves, each of maximum load bearing capacity 100 kg - shelves mounted by means of steel hooks - shelves adjustable every 25 mm - a rack is provided with a set of angle braces, in order to increase its stability - racks can be coupled by means of common angle braces <p>Maximum allowable load on the completely assembled rack with angle braces (regardless of the number and types of shelves) - 600 kg</p>
	RGŁ ZP/2500/492 /6P	2500 x 1070 x 492/ 490 (41)	
	RGŁ ZP/2500/592 /6P	2500 x 1070 x 592/ 590 (53)	

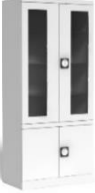
ADDITIONAL EQUIPMENT OPTIONS AVAILABLE IN RACKS ASSEMBLED WITH SCREWS OR CATHES

1 extra shelf 390 deep with allowable maximum load 100 kg
1 extra shelf 490 deep with allowable maximum load 100 kg
1 extra shelf 590 deep with allowable maximum load 100 kg
1 extra shelf with reinforcement 390 deep with allowable maximum load 150 kg
1 extra shelf with reinforcement 490 deep with allowable maximum load 150 kg
1 extra shelf with reinforcement 590 deep with allowable maximum load 150 kg
Surcharge to reinforcement of 5 shelves in RGŁ SK/2000/390/5P, RGŁ SK/2000/490/5P and RGŁ SK/2000/590/5P, as well as RGŁ ZP/2000/390/5P, RGŁ ZP/2000/490/5P and RGŁ ZP/2000/590/5P
Surcharge to reinforcement of 6 shelves in RGŁ SK/2500/390/6P, RGŁ SK/2500/490/6P and RGŁ SK/2500/590/6P, as well as RGŁ ZP/2500/390/6P, RGŁ ZP/2500/490/6P and RGŁ ZP/2500/590/6P

MEDICAL CABINETS			
	<p>Hinged doors are provided with reinforced inner profile, the doors (and side walls of the cabinet) are provided with safety glass 4.2 [mm] thick,</p> <ul style="list-style-type: none"> - doors are locked with a key lock with a hand wheel, with 2-point locking system <p>Perforated profiles inside the cabinet are provided to adjust the shelf height every 25 mm.</p> <ul style="list-style-type: none"> - shelves made of safety tempered glass 6 [mm] thick, - shelves are placed on steel brackets covered with felt. <p><i>Our products are covered by 24-months warranty, whereas the locks are covered by 12-months warranty.</i></p> <p><i>Cabinets painted with all RAL colours.</i></p> <p><i>Delivered cabinets are completely assembled, still shelves need to be mounted.</i></p>		
	SKU	DIMENSIONS [mm] H x W x D (WEIGHT [kg])	ADDITIONAL DESCRIPTION
1-door cabinet with glass door			
	SLA 1H 600/OP	1800 X 600 X 435 (60)	4 adjustable shelves
1-door cabinet with glass door			
	SLA DH 600/OD	1800 x 600 x 435 (61)	<p>Top section (external dimensions W 600 mm x H 1133 mm x D 435 mm):</p> <ul style="list-style-type: none"> - 1-door with safety glass 4.2 mm thick (glass dimensions: 202 mm x 1003 mm) - 3 glass shelves, adjustable every 25 mm <p>Bottom section (external dimensions W 600 mm x H 495 mm x D 435 mm; useful dimensions H 495 mm x W 550 x D 395 mm):</p> <ul style="list-style-type: none"> - full hinged door, - 1 glass shelf, adjustable every 25 mm <p>Doors locked with a key lock with a hand wheel, with 2-point locking system,</p>

2-door cabinet with glass door			
	SLA 2H 800/OP	1800 x 800 x 435 (85)	4 adjustable shelves
2-door cabinet with complete glass door			
	SLA 2H 800/OH	1800 x 800 x 435 (85)	4 adjustable shelves
	SLA 2H 1000/OH	1800 x 1000 x 435 (105)	
2-door cabinet with glass door and a locker			
	SLA DH 800/OD	1800 x 800 x 435 (85)	<p>Top section:</p> <ul style="list-style-type: none"> - 2-doors, with safety glass 4.2 mm thick, - 3 glass shelves, adjustable every 25 mm <p>Bottom section (useful dimensions [mm]: 495 H x 459 W x 395 D)</p> <ul style="list-style-type: none"> - full hinged door, - 1 glass shelf, adjustable every 25 mm <p>Doors locked with a key lock with a hand wheel, with 2-point locking system,</p>





ADDITIONAL EQUIPMENT OPTIONS AVAILABLE IN MEDICAL CABINETS

4 casters, including 2 casters with brake

Stands 100 mm H (4 pcs.)

Levelling feet (4 pcs.)

UV printing on the glass (1 pc of printing)

WALL-MOUNTED MEDICAL CUPBOARDS			
		<p>Our products are covered by 24-months warranty. Cupboards painted with all RAL colours. Delivered cupboards are completely assembled, still shelves need to be mounted.</p>	
	SKU	DIMENSIONS [mm] H x W x D (WEIGHT [kg])	ADDITIONAL DESCRIPTION
Cupboard with single hinged door			
		SMW 400	500 x 400 x 250 (10)
<p>Wall-mounted cupboard with single hinged door, a handle and a magnetic latch,</p> <p>A cupboard is provided with two shelves made of safety glass mounted on a permanently fixed angle brackets,</p> <p>Back wall is provided with openings to mount the cupboard on the wall.</p>			
Wall-mounted cupboard with sliding door			
800		SMW 800	500 x 800 x 250
1000		SMW 1000	500 x 1000 x 250 (30)
<p>Cupboard with sliding doors mounted on guide rails,</p> <ul style="list-style-type: none"> - doors are provided with handles to slide the doors, - shelves made of safety tempered glass 6 [mm] thick, giving clear access to the content, shelves are mounted on a permanently fixed angle brackets, - back wall is provided with openings to mount the cupboard on the wall. 			

FREE-STANDING MEDICAL CUPBOARDS



A cupboard is provided with a base unit of 81 mm, while mounting rails inside the cupboard are provided to adjust the shelf height every 25 mm,

Hinged doors are provided with reinforcing inner profile,

Doors are provided with internal hinges, giving free access to the furniture interior,

Doors are locked with a key lock with a hand wheel, with 3-point locking system,





Laminated top is fastened from its bottom side to the cupboard,



A cupboard is provided with levelling feet.



Our products are covered by 24-months warranty.

Cupboards painted with all RAL colours.

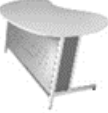
Delivered cupboards are completely assembled, still shelves need to be mounted.

	SKU	DIMENSIONS [mm] H x W x D (WEIGHT [kg])	ADDITIONAL DESCRIPTION
	SMS 745	745 x 500 x 420 (20)	1 adjustable shelf
	SMS 1030	1030 x 500 x 420 (25)	2 adjustable shelves
	SMS 1315	1315 x 500 x 420 (30)	3 adjustable shelves
	SMS 1600	1600 x 500 x 420 (35)	1 adjustable shelf with a rail and hooks

MEDICAL DESK			
 <p>Frame in the medical desks is made of full steel profiles with quadrangle cross-section, and is provided with levelling feet.</p> <p>Kidney-shaped table-top 25 mm thick is coated with grey laminate.</p> <p>A desk is provided with 1 metal perforated front blinder and 2 metal side blinders.</p> <p><i>Our products are covered by 24-months warranty. Desks are painted with all RAL colours. Delivered desks need to be assembled, top needs to be mounted.</i></p>			
	SKU	DIMENSIONS [mm] H x W x D (WEIGHT [kg])	ADDITIONAL DESCRIPTION
	BL1	740 x 1800 x 800 (44)	

MEDICAL FILE CABINETS			
		<p><i>Our products are covered by 24-months warranty. Cabinets are painted with all RAL colours. Delivered cabinets are completely assembled, still shelves need to be mounted.</i></p>	
	SKU	DIMENSIONS [mm] H x W x D (WEIGHT [kg])	ADDITIONAL DESCRIPTION
2-doors medical file cabinet			
	SZAM 2D800/400	2000 x 800 x 420 (55)	4 adjustable shelves
	SZAM 2D1000/400	2000 x 1000 x 420 (60)	
	SZAM 2D1200/400	2000 x 1200 x 420 (70)	